

JOHANNUS

SCHEMATTC DIAGRAMS

S W E E L I N C K I I I

ALTERATIONS RESERVED

JOHANNUS Orgelbouw b.v.

Morsestraat 28 - 6716 AH Ede - Tel. (08380) 37403 - Fax (08380) 22238

CONTENTS

1. BLOCK DIAGRAM ORGAN
2. BLOCK DIAGRAM RACK
3. POSITION DIAGRAM CARDS (TOPVIEW) & EXTERNAL CONNECTIONS (mounted on the rearside of the organ)
4. PINNING BUS CARD CONNECTORS
5. TRANSFORMER CONNECTIONS & POWER SUPPLY
6. SCANNING KEYING & TRANSPOSER
7. STOP-BANK & SWITCH-BANK CAPTURE SYSTEM
8. INPUT CIRCUIT SCANNING KEYING, TRANSPOSER & GENERAL CRESCENDO CIRCUIT (master processor)
9. INPUT CIRCUIT STOPS & CAPTURE SYSTEM (master processor)
10. C.P.U. (master processor)
11. PROCESSOR CARD (2x)
12. GENERATOR CARD (2x)
13. VOICE CARD (10x)
14. VOLUMECONTROLS; HEADPHONES CONNECTIONS & ECHO INTERFACE (ota card pedal/great)
15. VOLUMECONTROLS; HEADPHONES CONNECTIONS & ECHO INTERFACE (ota card choir/swell)
16. EXPRESSION PEDAL CIRCUIT (2x) (ota card)
17. AMPLIFIER CARD (4x)
18. POSITION DIAGRAM ADJUSTMENTS
INTERNAL POTENTIOMETERS

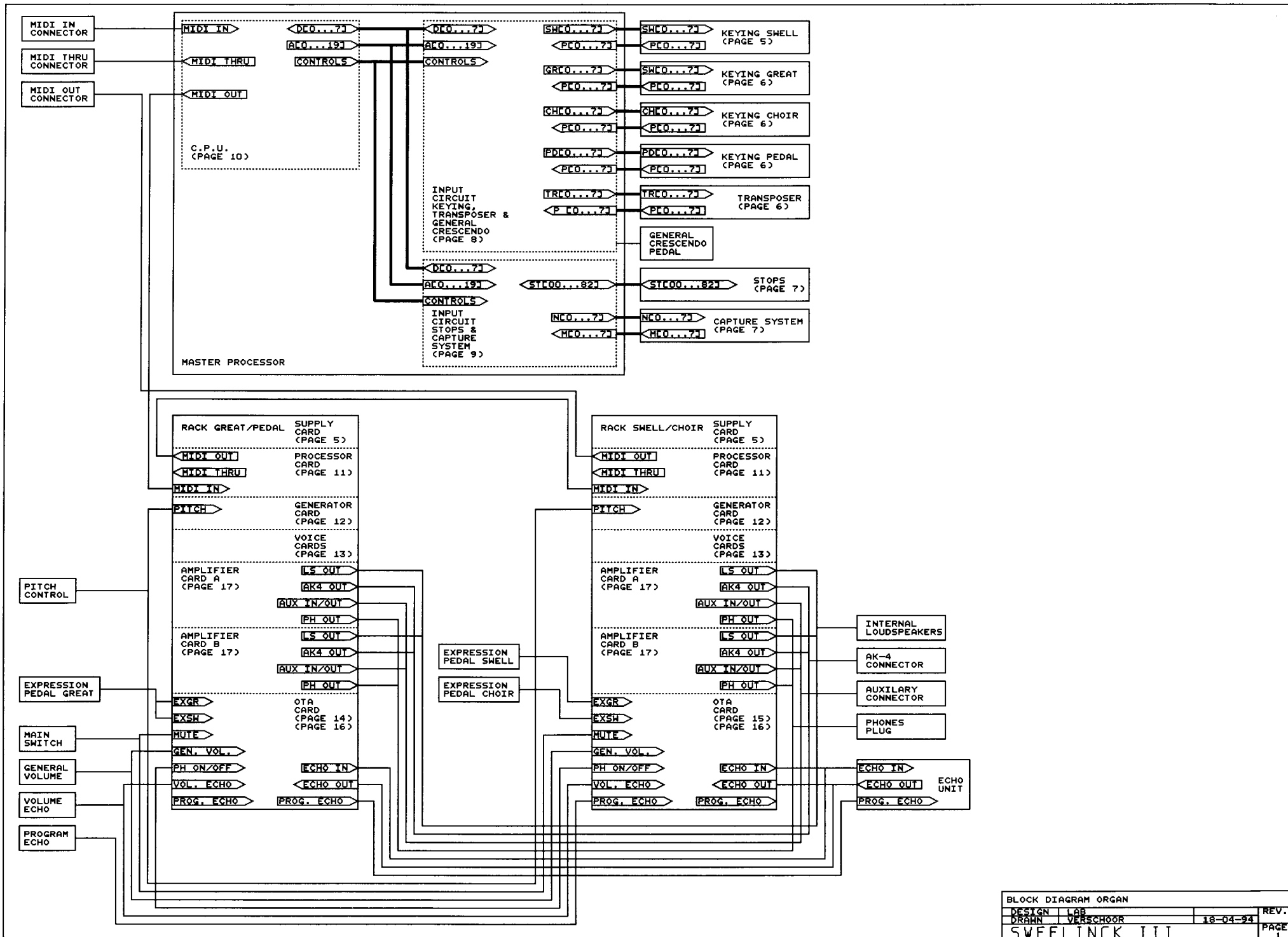

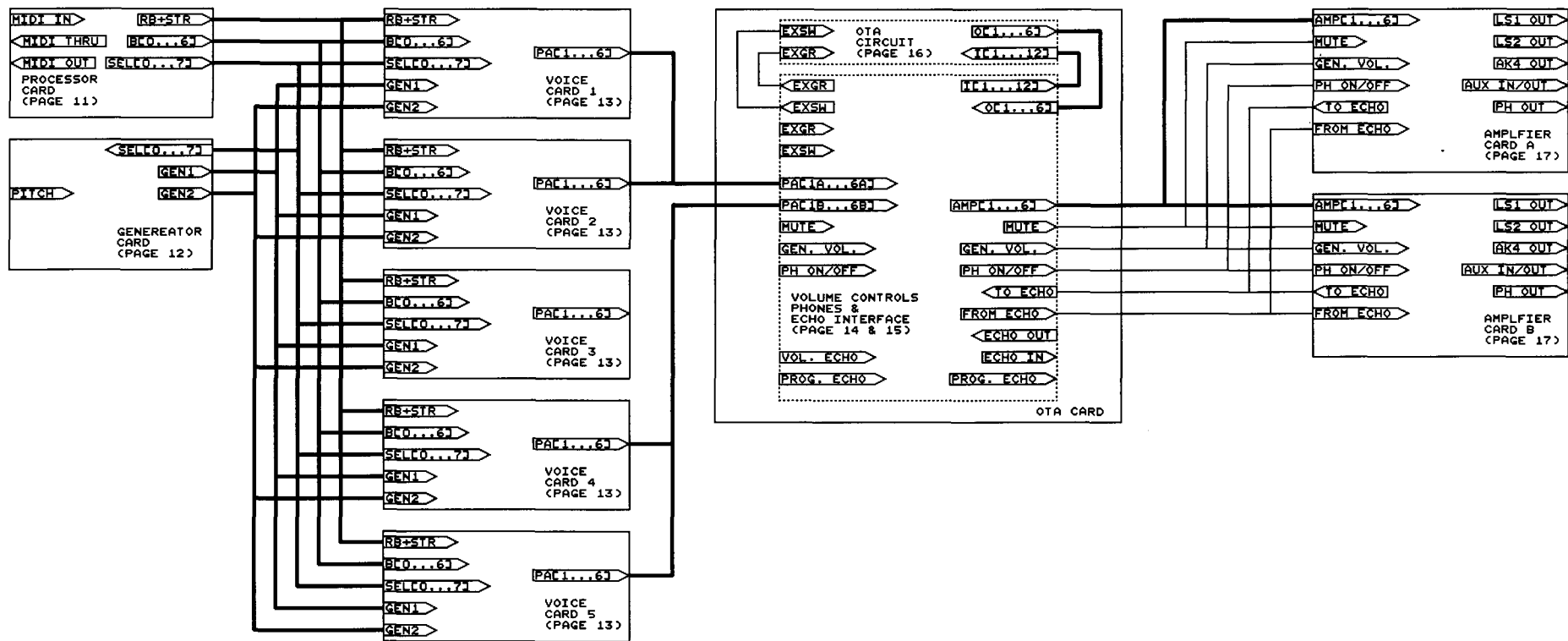

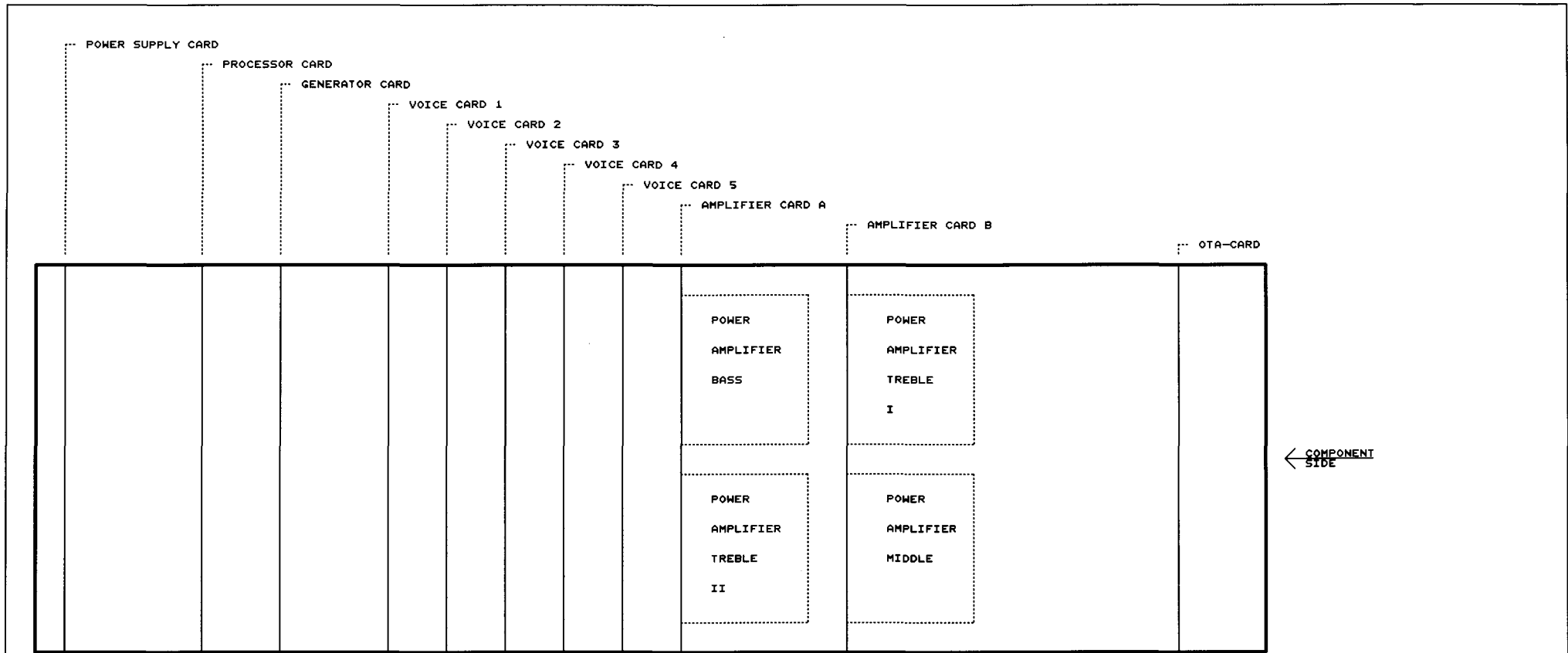

- 1. NOT CONNECTED
- 2. NOT CONNECTED
- 3. NOT CONNECTED
- 4. +5V MIDI IN
- 5. MIDI IN

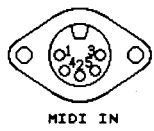

- 1. NOT CONNECTED
- 2. NOT CONNECTED
- 3. NOT CONNECTED
- 4. +5V MIDI THRU
- 5. MIDI THRU

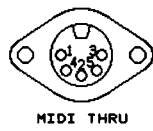

- 1. NOT CONNECTED
- 2. NOT CONNECTED
- 3. NOT CONNECTED
- 4. +5V MIDI OUT
- 5. MIDI OUT

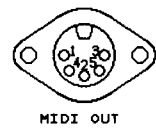

SOLDERING SIDE VIEW

- 1. AK-4 OUT CHANNEL A
- 2. GROUND
- 3. NOT CONNECTED
- 4. AK-4 OUT CHANNEL B
- 5. NOT CONNECTED

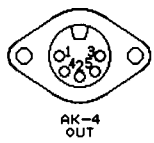

- 1. AUX OUT CHANNEL A
- 2. GROUND
- 3. AUX IN CHANNEL A
- 4. AUX OUT CHANNEL B
- 5. AUX IN CHANNEL B

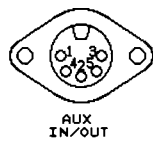

- 1. - BASS GREAT/PEDAL AMPLIFIER
- 2. + BASS GREAT/PEDAL AMPLIFIER
- 3. - MIDDLE GREAT/PEDAL AMPLIFIER
- 4. + MIDDLE GREAT/PEDAL AMPLIFIER
- 5. - TREBLE I PEDAL/GREAT AMPLIFIER
- 6. + TREBLE I PEDAL/GREAT AMPLIFIER
- 7. - TREBLE II GREAT/PEDAL AMPLIFIER
- 8. + TREBLE II GREAT/PEDAL AMPLIFIER

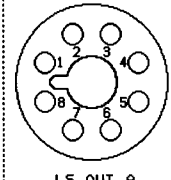

- 1. - BASS SWELL/CHOIR AMPLIFIER
- 2. + BASS SWELL/CHOIR AMPLIFIER
- 3. - MIDDLE SWELL/CHOIR AMPLIFIER
- 4. + MIDDLE SWELL/CHOIR AMPLIFIER
- 5. - TREBLE I SWELL/CHOIR AMPLIFIER
- 6. + TREBLE I SWELL/CHOIR AMPLIFIER
- 7. - TREBLE II SWELL/CHOIR AMPLIFIER
- 8. + TREBLE II SWELL/CHOIR AMPLIFIER

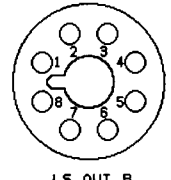

(OPTIONAL)

<p>CON1</p> <table border="0"> <tr><td>015</td><td></td><td></td><td></td></tr> <tr><td>020</td><td></td><td></td><td></td></tr> <tr><td>030</td><td></td><td></td><td></td></tr> <tr><td>040</td><td></td><td></td><td></td></tr> <tr><td>+12V</td><td>+12V</td><td></td><td></td></tr> <tr><td>-12V</td><td>-12V</td><td></td><td></td></tr> <tr><td>AGND</td><td>AGND</td><td></td><td></td></tr> <tr><td>AGND</td><td>AGND</td><td></td><td></td></tr> <tr><td>+35V</td><td>+35V</td><td></td><td></td></tr> <tr><td>-35V</td><td>-35V</td><td></td><td></td></tr> <tr><td>010</td><td></td><td></td><td></td></tr> <tr><td>012</td><td></td><td></td><td></td></tr> <tr><td>013</td><td></td><td></td><td></td></tr> <tr><td>014</td><td></td><td></td><td></td></tr> <tr><td>015</td><td></td><td></td><td></td></tr> <tr><td>016</td><td></td><td></td><td></td></tr> <tr><td>017</td><td></td><td></td><td></td></tr> <tr><td>018</td><td></td><td></td><td></td></tr> <tr><td>019</td><td></td><td></td><td></td></tr> <tr><td>020</td><td></td><td></td><td></td></tr> <tr><td>021</td><td></td><td></td><td></td></tr> <tr><td>022</td><td></td><td></td><td></td></tr> <tr><td>023</td><td></td><td></td><td></td></tr> <tr><td>024</td><td></td><td></td><td></td></tr> <tr><td>025</td><td></td><td></td><td></td></tr> <tr><td>026</td><td></td><td></td><td></td></tr> <tr><td>027</td><td></td><td></td><td></td></tr> <tr><td>028</td><td></td><td></td><td></td></tr> <tr><td>029</td><td></td><td></td><td></td></tr> <tr><td>030</td><td></td><td></td><td></td></tr> <tr><td>031</td><td></td><td></td><td></td></tr> <tr><td>032</td><td></td><td></td><td></td></tr> <tr><td>032c</td><td></td><td></td><td></td></tr> </table> <p>POWER SUPPLY CARD</p>	015				020				030				040				+12V	+12V			-12V	-12V			AGND	AGND			AGND	AGND			+35V	+35V			-35V	-35V			010				012				013				014				015				016				017				018				019				020				021				022				023				024				025				026				027				028				029				030				031				032				032c				<p>CON2</p> <table border="0"> <tr><td>015</td><td></td><td></td><td></td></tr> <tr><td>020</td><td></td><td></td><td></td></tr> <tr><td>030</td><td></td><td></td><td></td></tr> <tr><td>040</td><td></td><td></td><td></td></tr> <tr><td>+12V</td><td>+12V</td><td></td><td></td></tr> <tr><td>-12V</td><td>-12V</td><td></td><td></td></tr> <tr><td>AGND</td><td>AGND</td><td></td><td></td></tr> <tr><td>AGND</td><td>AGND</td><td></td><td></td></tr> <tr><td>+35V</td><td>+35V</td><td></td><td></td></tr> <tr><td>-35V</td><td>-35V</td><td></td><td></td></tr> <tr><td>010</td><td></td><td></td><td></td></tr> <tr><td>012</td><td></td><td></td><td></td></tr> <tr><td>013</td><td></td><td></td><td></td></tr> <tr><td>014</td><td></td><td></td><td></td></tr> <tr><td>015</td><td></td><td></td><td></td></tr> <tr><td>016</td><td></td><td></td><td></td></tr> <tr><td>017</td><td></td><td></td><td></td></tr> <tr><td>018</td><td></td><td></td><td></td></tr> <tr><td>019</td><td></td><td></td><td></td></tr> <tr><td>020</td><td></td><td></td><td></td></tr> <tr><td>B6</td><td></td><td></td><td></td></tr> <tr><td>B4</td><td></td><td></td><td></td></tr> <tr><td>B2</td><td></td><td></td><td></td></tr> <tr><td>B0</td><td></td><td></td><td></td></tr> <tr><td>025</td><td></td><td></td><td></td></tr> <tr><td>026</td><td></td><td></td><td></td></tr> <tr><td>027</td><td></td><td></td><td></td></tr> <tr><td>028</td><td></td><td></td><td></td></tr> <tr><td>029</td><td></td><td></td><td></td></tr> <tr><td>030</td><td></td><td></td><td></td></tr> <tr><td>031</td><td></td><td></td><td></td></tr> <tr><td>032</td><td></td><td></td><td></td></tr> <tr><td>032c</td><td></td><td></td><td></td></tr> </table> <p>PROCESSOR CARD</p>	015				020				030				040				+12V	+12V			-12V	-12V			AGND	AGND			AGND	AGND			+35V	+35V			-35V	-35V			010				012				013				014				015				016				017				018				019				020				B6				B4				B2				B0				025				026				027				028				029				030				031				032				032c				<p>CON3</p> <table border="0"> <tr><td>015</td><td></td><td></td><td></td></tr> <tr><td>020</td><td></td><td></td><td></td></tr> <tr><td>030</td><td></td><td></td><td></td></tr> <tr><td>040</td><td></td><td></td><td></td></tr> <tr><td>+12V</td><td>+12V</td><td></td><td></td></tr> <tr><td>-12V</td><td>-12V</td><td></td><td></td></tr> <tr><td>AGND</td><td>AGND</td><td></td><td></td></tr> <tr><td>AGND</td><td>AGND</td><td></td><td></td></tr> <tr><td>+35V</td><td>+35V</td><td></td><td></td></tr> <tr><td>-35V</td><td>-35V</td><td></td><td></td></tr> <tr><td>010</td><td></td><td></td><td></td></tr> <tr><td>012</td><td></td><td></td><td></td></tr> <tr><td>013</td><td></td><td></td><td></td></tr> <tr><td>014</td><td></td><td></td><td></td></tr> <tr><td>015</td><td></td><td></td><td></td></tr> <tr><td>016</td><td></td><td></td><td></td></tr> <tr><td>017</td><td></td><td></td><td></td></tr> <tr><td>018</td><td></td><td></td><td></td></tr> <tr><td>019</td><td></td><td></td><td></td></tr> <tr><td>020</td><td></td><td></td><td></td></tr> <tr><td>B6</td><td></td><td></td><td></td></tr> <tr><td>B4</td><td></td><td></td><td></td></tr> <tr><td>B2</td><td></td><td></td><td></td></tr> <tr><td>B0</td><td></td><td></td><td></td></tr> <tr><td>025</td><td></td><td></td><td></td></tr> <tr><td>026</td><td></td><td></td><td></td></tr> <tr><td>027</td><td></td><td></td><td></td></tr> <tr><td>028</td><td></td><td></td><td></td></tr> <tr><td>029</td><td></td><td></td><td></td></tr> <tr><td>030</td><td></td><td></td><td></td></tr> <tr><td>031</td><td></td><td></td><td></td></tr> <tr><td>032</td><td></td><td></td><td></td></tr> <tr><td>032c</td><td></td><td></td><td></td></tr> </table> <p>GENERATOR CARD</p>	015				020				030				040				+12V	+12V			-12V	-12V			AGND	AGND			AGND	AGND			+35V	+35V			-35V	-35V			010				012				013				014				015				016				017				018				019				020				B6				B4				B2				B0				025				026				027				028				029				030				031				032				032c				<p>CON4-5</p> <table border="0"> <tr><td>PA1B</td><td>015</td><td>PA2B</td><td></td></tr> <tr><td>PA3B</td><td>020</td><td>PA4B</td><td></td></tr> <tr><td>PA5B</td><td>030</td><td>PA6B</td><td></td></tr> <tr><td>040</td><td></td><td></td><td></td></tr> <tr><td>+12V</td><td>+12V</td><td></td><td></td></tr> <tr><td>-12V</td><td>-12V</td><td></td><td></td></tr> <tr><td>AGND</td><td>AGND</td><td></td><td></td></tr> <tr><td>AGND</td><td>AGND</td><td></td><td></td></tr> <tr><td>+35V</td><td>+35V</td><td></td><td></td></tr> <tr><td>-35V</td><td>-35V</td><td></td><td></td></tr> <tr><td>010</td><td></td><td></td><td></td></tr> <tr><td>012</td><td></td><td></td><td></td></tr> <tr><td>013</td><td></td><td></td><td></td></tr> <tr><td>014</td><td></td><td></td><td></td></tr> <tr><td>015</td><td></td><td></td><td></td></tr> <tr><td>016</td><td></td><td></td><td></td></tr> <tr><td>017</td><td></td><td></td><td></td></tr> <tr><td>018</td><td></td><td></td><td></td></tr> <tr><td>019</td><td></td><td></td><td></td></tr> <tr><td>020</td><td></td><td></td><td></td></tr> <tr><td>B6</td><td></td><td></td><td></td></tr> <tr><td>B4</td><td></td><td></td><td></td></tr> <tr><td>B2</td><td></td><td></td><td></td></tr> <tr><td>B0</td><td></td><td></td><td></td></tr> <tr><td>025</td><td></td><td></td><td></td></tr> <tr><td>026</td><td></td><td></td><td></td></tr> <tr><td>027</td><td></td><td></td><td></td></tr> <tr><td>028</td><td></td><td></td><td></td></tr> <tr><td>029</td><td></td><td></td><td></td></tr> <tr><td>030</td><td></td><td></td><td></td></tr> <tr><td>031</td><td></td><td></td><td></td></tr> <tr><td>032</td><td></td><td></td><td></td></tr> <tr><td>032c</td><td></td><td></td><td></td></tr> </table> <p>VOICE CARD 1-2</p>	PA1B	015	PA2B		PA3B	020	PA4B		PA5B	030	PA6B		040				+12V	+12V			-12V	-12V			AGND	AGND			AGND	AGND			+35V	+35V			-35V	-35V			010				012				013				014				015				016				017				018				019				020				B6				B4				B2				B0				025				026				027				028				029				030				031				032				032c				<p>CON6-8</p> <table border="0"> <tr><td>PA1A</td><td>015</td><td>PA2A</td><td></td></tr> <tr><td>PA3A</td><td>020</td><td>PA4A</td><td></td></tr> <tr><td>PA5A</td><td>030</td><td>PA6A</td><td></td></tr> <tr><td>040</td><td></td><td>PA7A</td><td></td></tr> <tr><td>+12V</td><td>+12V</td><td></td><td></td></tr> <tr><td>-12V</td><td>-12V</td><td></td><td></td></tr> <tr><td>AGND</td><td>AGND</td><td></td><td></td></tr> <tr><td>AGND</td><td>AGND</td><td></td><td></td></tr> <tr><td>+35V</td><td>+35V</td><td></td><td></td></tr> <tr><td>-35V</td><td>-35V</td><td></td><td></td></tr> <tr><td>010</td><td></td><td></td><td></td></tr> <tr><td>012</td><td></td><td></td><td></td></tr> <tr><td>013</td><td></td><td></td><td></td></tr> <tr><td>014</td><td></td><td></td><td></td></tr> <tr><td>015</td><td></td><td></td><td></td></tr> <tr><td>016</td><td></td><td></td><td></td></tr> <tr><td>017</td><td></td><td></td><td></td></tr> <tr><td>018</td><td></td><td></td><td></td></tr> <tr><td>019</td><td></td><td></td><td></td></tr> <tr><td>020</td><td></td><td></td><td></td></tr> <tr><td>B6</td><td></td><td></td><td></td></tr> <tr><td>B4</td><td></td><td></td><td></td></tr> <tr><td>B2</td><td></td><td></td><td></td></tr> <tr><td>B0</td><td></td><td></td><td></td></tr> <tr><td>025</td><td></td><td></td><td></td></tr> <tr><td>026</td><td></td><td></td><td></td></tr> <tr><td>027</td><td></td><td></td><td></td></tr> <tr><td>028</td><td></td><td></td><td></td></tr> <tr><td>029</td><td></td><td></td><td></td></tr> <tr><td>030</td><td></td><td></td><td></td></tr> <tr><td>031</td><td></td><td></td><td></td></tr> <tr><td>032</td><td></td><td></td><td></td></tr> <tr><td>032c</td><td></td><td></td><td></td></tr> </table> <p>VOICE CARD 3-5</p>	PA1A	015	PA2A		PA3A	020	PA4A		PA5A	030	PA6A		040		PA7A		+12V	+12V			-12V	-12V			AGND	AGND			AGND	AGND			+35V	+35V			-35V	-35V			010				012				013				014				015				016				017				018				019				020				B6				B4				B2				B0				025				026				027				028				029				030				031				032				032c				<p>CON9-10</p> <table border="0"> <tr><td>AMP1</td><td>015</td><td>AMP2</td><td></td></tr> <tr><td>AMP3</td><td>020</td><td>AMP4</td><td></td></tr> <tr><td>TO ECHO</td><td>030</td><td>FROM ECHO B</td><td></td></tr> <tr><td>040</td><td></td><td>FROM ECHO A</td><td></td></tr> <tr><td>+12V</td><td>+12V</td><td></td><td></td></tr> <tr><td>-12V</td><td>-12V</td><td></td><td></td></tr> <tr><td>AGND</td><td>AGND</td><td></td><td></td></tr> <tr><td>AGND</td><td>AGND</td><td></td><td></td></tr> <tr><td>+35V</td><td>+35V</td><td></td><td></td></tr> <tr><td>-35V</td><td>-35V</td><td></td><td></td></tr> <tr><td>010</td><td></td><td></td><td></td></tr> <tr><td>012</td><td></td><td></td><td></td></tr> <tr><td>013</td><td></td><td></td><td></td></tr> <tr><td>014</td><td></td><td></td><td></td></tr> <tr><td>015</td><td></td><td></td><td></td></tr> <tr><td>016</td><td></td><td></td><td></td></tr> <tr><td>017</td><td></td><td></td><td></td></tr> <tr><td>018</td><td></td><td></td><td></td></tr> <tr><td>019</td><td></td><td></td><td></td></tr> <tr><td>020</td><td></td><td></td><td></td></tr> <tr><td>B6</td><td></td><td></td><td></td></tr> <tr><td>B4</td><td></td><td></td><td></td></tr> <tr><td>B2</td><td></td><td></td><td></td></tr> <tr><td>B0</td><td></td><td></td><td></td></tr> <tr><td>025</td><td></td><td></td><td></td></tr> <tr><td>026</td><td></td><td></td><td></td></tr> <tr><td>027</td><td></td><td></td><td></td></tr> <tr><td>028</td><td></td><td></td><td></td></tr> <tr><td>029</td><td></td><td></td><td></td></tr> <tr><td>030</td><td></td><td></td><td></td></tr> <tr><td>031</td><td></td><td></td><td></td></tr> <tr><td>032</td><td></td><td></td><td></td></tr> <tr><td>032c</td><td></td><td></td><td></td></tr> </table> <p>AMPLIFIER CARD A & B</p>	AMP1	015	AMP2		AMP3	020	AMP4		TO ECHO	030	FROM ECHO B		040		FROM ECHO A		+12V	+12V			-12V	-12V			AGND	AGND			AGND	AGND			+35V	+35V			-35V	-35V			010				012				013				014				015				016				017				018				019				020				B6				B4				B2				B0				025				026				027				028				029				030				031				032				032c				<p>CON11</p> <table border="0"> <tr><td>AMP3</td><td>015</td><td>AMP4</td><td></td></tr> <tr><td>AMP5</td><td>020</td><td>AMP6</td><td></td></tr> <tr><td>TO ECHO</td><td>030</td><td>FROM ECHO B</td><td></td></tr> <tr><td>040</td><td></td><td>FROM ECHO A</td><td></td></tr> <tr><td>+12V</td><td>+12V</td><td></td><td></td></tr> <tr><td>-12V</td><td>-12V</td><td></td><td></td></tr> <tr><td>AGND</td><td>AGND</td><td></td><td></td></tr> <tr><td>AGND</td><td>AGND</td><td></td><td></td></tr> <tr><td>+35V</td><td>+35V</td><td></td><td></td></tr> <tr><td>-35V</td><td>-35V</td><td></td><td></td></tr> <tr><td>010</td><td></td><td></td><td></td></tr> <tr><td>012</td><td></td><td></td><td></td></tr> <tr><td>013</td><td></td><td></td><td></td></tr> <tr><td>014</td><td></td><td></td><td></td></tr> <tr><td>015</td><td></td><td></td><td></td></tr> <tr><td>016</td><td></td><td></td><td></td></tr> <tr><td>017</td><td></td><td></td><td></td></tr> <tr><td>018</td><td></td><td></td><td></td></tr> <tr><td>019</td><td></td><td></td><td></td></tr> <tr><td>020</td><td></td><td></td><td></td></tr> <tr><td>B6</td><td></td><td></td><td></td></tr> <tr><td>B4</td><td></td><td></td><td></td></tr> <tr><td>B2</td><td></td><td></td><td></td></tr> <tr><td>B0</td><td></td><td></td><td></td></tr> <tr><td>025</td><td></td><td></td><td></td></tr> <tr><td>026</td><td></td><td></td><td></td></tr> <tr><td>027</td><td></td><td></td><td></td></tr> <tr><td>028</td><td></td><td></td><td></td></tr> <tr><td>029</td><td></td><td></td><td></td></tr> <tr><td>030</td><td></td><td></td><td></td></tr> <tr><td>031</td><td></td><td></td><td></td></tr> <tr><td>032</td><td></td><td></td><td></td></tr> <tr><td>032c</td><td></td><td></td><td></td></tr> </table> <p>AMPLIFIER CARD C</p>	AMP3	015	AMP4		AMP5	020	AMP6		TO ECHO	030	FROM ECHO B		040		FROM ECHO A		+12V	+12V			-12V	-12V			AGND	AGND			AGND	AGND			+35V	+35V			-35V	-35V			010				012				013				014				015				016				017				018				019				020				B6				B4				B2				B0				025				026				027				028				029				030				031				032				032c				<p>CON12</p> <table border="0"> <tr><td>AMP1</td><td>015</td><td>AMP2</td><td></td></tr> <tr><td>AMP3</td><td>020</td><td>AMP4</td><td></td></tr> <tr><td>AMP5</td><td>030</td><td>AMP6</td><td></td></tr> <tr><td>FROM ECHO A</td><td>040</td><td>FROM ECHO B</td><td></td></tr> <tr><td>+12V</td><td>+12V</td><td></td><td></td></tr> <tr><td>-12V</td><td>-12V</td><td></td><td></td></tr> <tr><td>AGND</td><td>AGND</td><td></td><td></td></tr> <tr><td>AGND</td><td>AGND</td><td></td><td></td></tr> <tr><td>+35V</td><td>+35V</td><td></td><td></td></tr> <tr><td>-35V</td><td>-35V</td><td></td><td></td></tr> <tr><td>010</td><td></td><td></td><td></td></tr> <tr><td>012</td><td></td><td></td><td></td></tr> <tr><td>013</td><td></td><td></td><td></td></tr> <tr><td>014</td><td></td><td></td><td></td></tr> <tr><td>015</td><td></td><td></td><td></td></tr> <tr><td>016</td><td></td><td></td><td></td></tr> <tr><td>017</td><td></td><td></td><td></td></tr> <tr><td>018</td><td></td><td></td><td></td></tr> <tr><td>019</td><td></td><td></td><td></td></tr> <tr><td>020</td><td></td><td></td><td></td></tr> <tr><td>021</td><td></td><td></td><td></td></tr> <tr><td>022</td><td></td><td></td><td></td></tr> <tr><td>023</td><td></td><td></td><td></td></tr> <tr><td>024</td><td></td><td></td><td></td></tr> <tr><td>025</td><td></td><td></td><td></td></tr> <tr><td>026</td><td></td><td></td><td></td></tr> <tr><td>027</td><td></td><td></td><td></td></tr> <tr><td>028</td><td></td><td></td><td></td></tr> <tr><td>029</td><td></td><td></td><td></td></tr> <tr><td>030</td><td></td><td></td><td></td></tr> <tr><td>031</td><td></td><td></td><td></td></tr> <tr><td>032</td><td></td><td></td><td></td></tr> <tr><td>032c</td><td></td><td></td><td></td></tr> </table> <p>OTA CARD</p>	AMP1	015	AMP2		AMP3	020	AMP4		AMP5	030	AMP6		FROM ECHO A	040	FROM ECHO B		+12V	+12V			-12V	-12V			AGND	AGND			AGND	AGND			+35V	+35V			-35V	-35V			010				012				013				014				015				016				017				018				019				020				021				022				023				024				025				026				027				028				029				030				031				032				032c			
015																																																																																																																																																																																																																																																																																																																																																																																																																																																																																																																																																																																																																																																																																																																																																																																																																																																																																																																																																																																																																																																																																																							
020																																																																																																																																																																																																																																																																																																																																																																																																																																																																																																																																																																																																																																																																																																																																																																																																																																																																																																																																																																																																																																																																																																							
030																																																																																																																																																																																																																																																																																																																																																																																																																																																																																																																																																																																																																																																																																																																																																																																																																																																																																																																																																																																																																																																																																																							
040																																																																																																																																																																																																																																																																																																																																																																																																																																																																																																																																																																																																																																																																																																																																																																																																																																																																																																																																																																																																																																																																																																							
+12V	+12V																																																																																																																																																																																																																																																																																																																																																																																																																																																																																																																																																																																																																																																																																																																																																																																																																																																																																																																																																																																																																																																																																																						
-12V	-12V																																																																																																																																																																																																																																																																																																																																																																																																																																																																																																																																																																																																																																																																																																																																																																																																																																																																																																																																																																																																																																																																																																						
AGND	AGND																																																																																																																																																																																																																																																																																																																																																																																																																																																																																																																																																																																																																																																																																																																																																																																																																																																																																																																																																																																																																																																																																																						
AGND	AGND																																																																																																																																																																																																																																																																																																																																																																																																																																																																																																																																																																																																																																																																																																																																																																																																																																																																																																																																																																																																																																																																																																						
+35V	+35V																																																																																																																																																																																																																																																																																																																																																																																																																																																																																																																																																																																																																																																																																																																																																																																																																																																																																																																																																																																																																																																																																																						
-35V	-35V																																																																																																																																																																																																																																																																																																																																																																																																																																																																																																																																																																																																																																																																																																																																																																																																																																																																																																																																																																																																																																																																																																						
010																																																																																																																																																																																																																																																																																																																																																																																																																																																																																																																																																																																																																																																																																																																																																																																																																																																																																																																																																																																																																																																																																																							
012																																																																																																																																																																																																																																																																																																																																																																																																																																																																																																																																																																																																																																																																																																																																																																																																																																																																																																																																																																																																																																																																																																							
013																																																																																																																																																																																																																																																																																																																																																																																																																																																																																																																																																																																																																																																																																																																																																																																																																																																																																																																																																																																																																																																																																																							
014																																																																																																																																																																																																																																																																																																																																																																																																																																																																																																																																																																																																																																																																																																																																																																																																																																																																																																																																																																																																																																																																																																							
015																																																																																																																																																																																																																																																																																																																																																																																																																																																																																																																																																																																																																																																																																																																																																																																																																																																																																																																																																																																																																																																																																																							
016																																																																																																																																																																																																																																																																																																																																																																																																																																																																																																																																																																																																																																																																																																																																																																																																																																																																																																																																																																																																																																																																																																							
017																																																																																																																																																																																																																																																																																																																																																																																																																																																																																																																																																																																																																																																																																																																																																																																																																																																																																																																																																																																																																																																																																																							
018																																																																																																																																																																																																																																																																																																																																																																																																																																																																																																																																																																																																																																																																																																																																																																																																																																																																																																																																																																																																																																																																																																							
019																																																																																																																																																																																																																																																																																																																																																																																																																																																																																																																																																																																																																																																																																																																																																																																																																																																																																																																																																																																																																																																																																																							
020																																																																																																																																																																																																																																																																																																																																																																																																																																																																																																																																																																																																																																																																																																																																																																																																																																																																																																																																																																																																																																																																																																							
021																																																																																																																																																																																																																																																																																																																																																																																																																																																																																																																																																																																																																																																																																																																																																																																																																																																																																																																																																																																																																																																																																																							
022																																																																																																																																																																																																																																																																																																																																																																																																																																																																																																																																																																																																																																																																																																																																																																																																																																																																																																																																																																																																																																																																																																							
023																																																																																																																																																																																																																																																																																																																																																																																																																																																																																																																																																																																																																																																																																																																																																																																																																																																																																																																																																																																																																																																																																																							
024																																																																																																																																																																																																																																																																																																																																																																																																																																																																																																																																																																																																																																																																																																																																																																																																																																																																																																																																																																																																																																																																																																							
025																																																																																																																																																																																																																																																																																																																																																																																																																																																																																																																																																																																																																																																																																																																																																																																																																																																																																																																																																																																																																																																																																																							
026																																																																																																																																																																																																																																																																																																																																																																																																																																																																																																																																																																																																																																																																																																																																																																																																																																																																																																																																																																																																																																																																																																							
027																																																																																																																																																																																																																																																																																																																																																																																																																																																																																																																																																																																																																																																																																																																																																																																																																																																																																																																																																																																																																																																																																																							
028																																																																																																																																																																																																																																																																																																																																																																																																																																																																																																																																																																																																																																																																																																																																																																																																																																																																																																																																																																																																																																																																																																							
029																																																																																																																																																																																																																																																																																																																																																																																																																																																																																																																																																																																																																																																																																																																																																																																																																																																																																																																																																																																																																																																																																																							
030																																																																																																																																																																																																																																																																																																																																																																																																																																																																																																																																																																																																																																																																																																																																																																																																																																																																																																																																																																																																																																																																																																							
031																																																																																																																																																																																																																																																																																																																																																																																																																																																																																																																																																																																																																																																																																																																																																																																																																																																																																																																																																																																																																																																																																																							
032																																																																																																																																																																																																																																																																																																																																																																																																																																																																																																																																																																																																																																																																																																																																																																																																																																																																																																																																																																																																																																																																																																							
032c																																																																																																																																																																																																																																																																																																																																																																																																																																																																																																																																																																																																																																																																																																																																																																																																																																																																																																																																																																																																																																																																																																							
015																																																																																																																																																																																																																																																																																																																																																																																																																																																																																																																																																																																																																																																																																																																																																																																																																																																																																																																																																																																																																																																																																																							
020																																																																																																																																																																																																																																																																																																																																																																																																																																																																																																																																																																																																																																																																																																																																																																																																																																																																																																																																																																																																																																																																																																							
030																																																																																																																																																																																																																																																																																																																																																																																																																																																																																																																																																																																																																																																																																																																																																																																																																																																																																																																																																																																																																																																																																																							
040																																																																																																																																																																																																																																																																																																																																																																																																																																																																																																																																																																																																																																																																																																																																																																																																																																																																																																																																																																																																																																																																																																							
+12V	+12V																																																																																																																																																																																																																																																																																																																																																																																																																																																																																																																																																																																																																																																																																																																																																																																																																																																																																																																																																																																																																																																																																																						
-12V	-12V																																																																																																																																																																																																																																																																																																																																																																																																																																																																																																																																																																																																																																																																																																																																																																																																																																																																																																																																																																																																																																																																																																						
AGND	AGND																																																																																																																																																																																																																																																																																																																																																																																																																																																																																																																																																																																																																																																																																																																																																																																																																																																																																																																																																																																																																																																																																																						
AGND	AGND																																																																																																																																																																																																																																																																																																																																																																																																																																																																																																																																																																																																																																																																																																																																																																																																																																																																																																																																																																																																																																																																																																						
+35V	+35V																																																																																																																																																																																																																																																																																																																																																																																																																																																																																																																																																																																																																																																																																																																																																																																																																																																																																																																																																																																																																																																																																																						
-35V	-35V																																																																																																																																																																																																																																																																																																																																																																																																																																																																																																																																																																																																																																																																																																																																																																																																																																																																																																																																																																																																																																																																																																						
010																																																																																																																																																																																																																																																																																																																																																																																																																																																																																																																																																																																																																																																																																																																																																																																																																																																																																																																																																																																																																																																																																																							
012																																																																																																																																																																																																																																																																																																																																																																																																																																																																																																																																																																																																																																																																																																																																																																																																																																																																																																																																																																																																																																																																																																							
013																																																																																																																																																																																																																																																																																																																																																																																																																																																																																																																																																																																																																																																																																																																																																																																																																																																																																																																																																																																																																																																																																																							
014																																																																																																																																																																																																																																																																																																																																																																																																																																																																																																																																																																																																																																																																																																																																																																																																																																																																																																																																																																																																																																																																																																							
015																																																																																																																																																																																																																																																																																																																																																																																																																																																																																																																																																																																																																																																																																																																																																																																																																																																																																																																																																																																																																																																																																																							
016																																																																																																																																																																																																																																																																																																																																																																																																																																																																																																																																																																																																																																																																																																																																																																																																																																																																																																																																																																																																																																																																																																							
017																																																																																																																																																																																																																																																																																																																																																																																																																																																																																																																																																																																																																																																																																																																																																																																																																																																																																																																																																																																																																																																																																																							
018																																																																																																																																																																																																																																																																																																																																																																																																																																																																																																																																																																																																																																																																																																																																																																																																																																																																																																																																																																																																																																																																																																							
019																																																																																																																																																																																																																																																																																																																																																																																																																																																																																																																																																																																																																																																																																																																																																																																																																																																																																																																																																																																																																																																																																																							
020																																																																																																																																																																																																																																																																																																																																																																																																																																																																																																																																																																																																																																																																																																																																																																																																																																																																																																																																																																																																																																																																																																							
B6																																																																																																																																																																																																																																																																																																																																																																																																																																																																																																																																																																																																																																																																																																																																																																																																																																																																																																																																																																																																																																																																																																							
B4																																																																																																																																																																																																																																																																																																																																																																																																																																																																																																																																																																																																																																																																																																																																																																																																																																																																																																																																																																																																																																																																																																							
B2																																																																																																																																																																																																																																																																																																																																																																																																																																																																																																																																																																																																																																																																																																																																																																																																																																																																																																																																																																																																																																																																																																							
B0																																																																																																																																																																																																																																																																																																																																																																																																																																																																																																																																																																																																																																																																																																																																																																																																																																																																																																																																																																																																																																																																																																							
025																																																																																																																																																																																																																																																																																																																																																																																																																																																																																																																																																																																																																																																																																																																																																																																																																																																																																																																																																																																																																																																																																																							
026																																																																																																																																																																																																																																																																																																																																																																																																																																																																																																																																																																																																																																																																																																																																																																																																																																																																																																																																																																																																																																																																																																							
027																																																																																																																																																																																																																																																																																																																																																																																																																																																																																																																																																																																																																																																																																																																																																																																																																																																																																																																																																																																																																																																																																																							
028																																																																																																																																																																																																																																																																																																																																																																																																																																																																																																																																																																																																																																																																																																																																																																																																																																																																																																																																																																																																																																																																																																							
029																																																																																																																																																																																																																																																																																																																																																																																																																																																																																																																																																																																																																																																																																																																																																																																																																																																																																																																																																																																																																																																																																																							
030																																																																																																																																																																																																																																																																																																																																																																																																																																																																																																																																																																																																																																																																																																																																																																																																																																																																																																																																																																																																																																																																																																							
031																																																																																																																																																																																																																																																																																																																																																																																																																																																																																																																																																																																																																																																																																																																																																																																																																																																																																																																																																																																																																																																																																																							
032																																																																																																																																																																																																																																																																																																																																																																																																																																																																																																																																																																																																																																																																																																																																																																																																																																																																																																																																																																																																																																																																																																							
032c																																																																																																																																																																																																																																																																																																																																																																																																																																																																																																																																																																																																																																																																																																																																																																																																																																																																																																																																																																																																																																																																																																							
015																																																																																																																																																																																																																																																																																																																																																																																																																																																																																																																																																																																																																																																																																																																																																																																																																																																																																																																																																																																																																																																																																																							
020																																																																																																																																																																																																																																																																																																																																																																																																																																																																																																																																																																																																																																																																																																																																																																																																																																																																																																																																																																																																																																																																																																							
030																																																																																																																																																																																																																																																																																																																																																																																																																																																																																																																																																																																																																																																																																																																																																																																																																																																																																																																																																																																																																																																																																																							
040																																																																																																																																																																																																																																																																																																																																																																																																																																																																																																																																																																																																																																																																																																																																																																																																																																																																																																																																																																																																																																																																																																							
+12V	+12V																																																																																																																																																																																																																																																																																																																																																																																																																																																																																																																																																																																																																																																																																																																																																																																																																																																																																																																																																																																																																																																																																																						
-12V	-12V																																																																																																																																																																																																																																																																																																																																																																																																																																																																																																																																																																																																																																																																																																																																																																																																																																																																																																																																																																																																																																																																																																						
AGND	AGND																																																																																																																																																																																																																																																																																																																																																																																																																																																																																																																																																																																																																																																																																																																																																																																																																																																																																																																																																																																																																																																																																																						
AGND	AGND																																																																																																																																																																																																																																																																																																																																																																																																																																																																																																																																																																																																																																																																																																																																																																																																																																																																																																																																																																																																																																																																																																						
+35V	+35V																																																																																																																																																																																																																																																																																																																																																																																																																																																																																																																																																																																																																																																																																																																																																																																																																																																																																																																																																																																																																																																																																																						
-35V	-35V																																																																																																																																																																																																																																																																																																																																																																																																																																																																																																																																																																																																																																																																																																																																																																																																																																																																																																																																																																																																																																																																																																						
010																																																																																																																																																																																																																																																																																																																																																																																																																																																																																																																																																																																																																																																																																																																																																																																																																																																																																																																																																																																																																																																																																																							
012																																																																																																																																																																																																																																																																																																																																																																																																																																																																																																																																																																																																																																																																																																																																																																																																																																																																																																																																																																																																																																																																																																							
013																																																																																																																																																																																																																																																																																																																																																																																																																																																																																																																																																																																																																																																																																																																																																																																																																																																																																																																																																																																																																																																																																																							
014																																																																																																																																																																																																																																																																																																																																																																																																																																																																																																																																																																																																																																																																																																																																																																																																																																																																																																																																																																																																																																																																																																							
015																																																																																																																																																																																																																																																																																																																																																																																																																																																																																																																																																																																																																																																																																																																																																																																																																																																																																																																																																																																																																																																																																																							
016																																																																																																																																																																																																																																																																																																																																																																																																																																																																																																																																																																																																																																																																																																																																																																																																																																																																																																																																																																																																																																																																																																							
017																																																																																																																																																																																																																																																																																																																																																																																																																																																																																																																																																																																																																																																																																																																																																																																																																																																																																																																																																																																																																																																																																																							
018																																																																																																																																																																																																																																																																																																																																																																																																																																																																																																																																																																																																																																																																																																																																																																																																																																																																																																																																																																																																																																																																																																							
019																																																																																																																																																																																																																																																																																																																																																																																																																																																																																																																																																																																																																																																																																																																																																																																																																																																																																																																																																																																																																																																																																																							
020																																																																																																																																																																																																																																																																																																																																																																																																																																																																																																																																																																																																																																																																																																																																																																																																																																																																																																																																																																																																																																																																																																							
B6																																																																																																																																																																																																																																																																																																																																																																																																																																																																																																																																																																																																																																																																																																																																																																																																																																																																																																																																																																																																																																																																																																							
B4																																																																																																																																																																																																																																																																																																																																																																																																																																																																																																																																																																																																																																																																																																																																																																																																																																																																																																																																																																																																																																																																																																							
B2																																																																																																																																																																																																																																																																																																																																																																																																																																																																																																																																																																																																																																																																																																																																																																																																																																																																																																																																																																																																																																																																																																							
B0																																																																																																																																																																																																																																																																																																																																																																																																																																																																																																																																																																																																																																																																																																																																																																																																																																																																																																																																																																																																																																																																																																							
025																																																																																																																																																																																																																																																																																																																																																																																																																																																																																																																																																																																																																																																																																																																																																																																																																																																																																																																																																																																																																																																																																																							
026																																																																																																																																																																																																																																																																																																																																																																																																																																																																																																																																																																																																																																																																																																																																																																																																																																																																																																																																																																																																																																																																																																							
027																																																																																																																																																																																																																																																																																																																																																																																																																																																																																																																																																																																																																																																																																																																																																																																																																																																																																																																																																																																																																																																																																																							
028																																																																																																																																																																																																																																																																																																																																																																																																																																																																																																																																																																																																																																																																																																																																																																																																																																																																																																																																																																																																																																																																																																							
029																																																																																																																																																																																																																																																																																																																																																																																																																																																																																																																																																																																																																																																																																																																																																																																																																																																																																																																																																																																																																																																																																																							
030																																																																																																																																																																																																																																																																																																																																																																																																																																																																																																																																																																																																																																																																																																																																																																																																																																																																																																																																																																																																																																																																																																							
031																																																																																																																																																																																																																																																																																																																																																																																																																																																																																																																																																																																																																																																																																																																																																																																																																																																																																																																																																																																																																																																																																																							
032																																																																																																																																																																																																																																																																																																																																																																																																																																																																																																																																																																																																																																																																																																																																																																																																																																																																																																																																																																																																																																																																																																							
032c																																																																																																																																																																																																																																																																																																																																																																																																																																																																																																																																																																																																																																																																																																																																																																																																																																																																																																																																																																																																																																																																																																							
PA1B	015	PA2B																																																																																																																																																																																																																																																																																																																																																																																																																																																																																																																																																																																																																																																																																																																																																																																																																																																																																																																																																																																																																																																																																																					
PA3B	020	PA4B																																																																																																																																																																																																																																																																																																																																																																																																																																																																																																																																																																																																																																																																																																																																																																																																																																																																																																																																																																																																																																																																																																					
PA5B	030	PA6B																																																																																																																																																																																																																																																																																																																																																																																																																																																																																																																																																																																																																																																																																																																																																																																																																																																																																																																																																																																																																																																																																																					
040																																																																																																																																																																																																																																																																																																																																																																																																																																																																																																																																																																																																																																																																																																																																																																																																																																																																																																																																																																																																																																																																																																							
+12V	+12V																																																																																																																																																																																																																																																																																																																																																																																																																																																																																																																																																																																																																																																																																																																																																																																																																																																																																																																																																																																																																																																																																																						
-12V	-12V																																																																																																																																																																																																																																																																																																																																																																																																																																																																																																																																																																																																																																																																																																																																																																																																																																																																																																																																																																																																																																																																																																						
AGND	AGND																																																																																																																																																																																																																																																																																																																																																																																																																																																																																																																																																																																																																																																																																																																																																																																																																																																																																																																																																																																																																																																																																																						
AGND	AGND																																																																																																																																																																																																																																																																																																																																																																																																																																																																																																																																																																																																																																																																																																																																																																																																																																																																																																																																																																																																																																																																																																						
+35V	+35V																																																																																																																																																																																																																																																																																																																																																																																																																																																																																																																																																																																																																																																																																																																																																																																																																																																																																																																																																																																																																																																																																																						
-35V	-35V																																																																																																																																																																																																																																																																																																																																																																																																																																																																																																																																																																																																																																																																																																																																																																																																																																																																																																																																																																																																																																																																																																						
010																																																																																																																																																																																																																																																																																																																																																																																																																																																																																																																																																																																																																																																																																																																																																																																																																																																																																																																																																																																																																																																																																																							
012																																																																																																																																																																																																																																																																																																																																																																																																																																																																																																																																																																																																																																																																																																																																																																																																																																																																																																																																																																																																																																																																																																							
013																																																																																																																																																																																																																																																																																																																																																																																																																																																																																																																																																																																																																																																																																																																																																																																																																																																																																																																																																																																																																																																																																																							
014																																																																																																																																																																																																																																																																																																																																																																																																																																																																																																																																																																																																																																																																																																																																																																																																																																																																																																																																																																																																																																																																																																							
015																																																																																																																																																																																																																																																																																																																																																																																																																																																																																																																																																																																																																																																																																																																																																																																																																																																																																																																																																																																																																																																																																																							
016																																																																																																																																																																																																																																																																																																																																																																																																																																																																																																																																																																																																																																																																																																																																																																																																																																																																																																																																																																																																																																																																																																							
017																																																																																																																																																																																																																																																																																																																																																																																																																																																																																																																																																																																																																																																																																																																																																																																																																																																																																																																																																																																																																																																																																																							
018																																																																																																																																																																																																																																																																																																																																																																																																																																																																																																																																																																																																																																																																																																																																																																																																																																																																																																																																																																																																																																																																																																							
019																																																																																																																																																																																																																																																																																																																																																																																																																																																																																																																																																																																																																																																																																																																																																																																																																																																																																																																																																																																																																																																																																																							
020																																																																																																																																																																																																																																																																																																																																																																																																																																																																																																																																																																																																																																																																																																																																																																																																																																																																																																																																																																																																																																																																																																							
B6																																																																																																																																																																																																																																																																																																																																																																																																																																																																																																																																																																																																																																																																																																																																																																																																																																																																																																																																																																																																																																																																																																							
B4																																																																																																																																																																																																																																																																																																																																																																																																																																																																																																																																																																																																																																																																																																																																																																																																																																																																																																																																																																																																																																																																																																							
B2																																																																																																																																																																																																																																																																																																																																																																																																																																																																																																																																																																																																																																																																																																																																																																																																																																																																																																																																																																																																																																																																																																							
B0																																																																																																																																																																																																																																																																																																																																																																																																																																																																																																																																																																																																																																																																																																																																																																																																																																																																																																																																																																																																																																																																																																							
025																																																																																																																																																																																																																																																																																																																																																																																																																																																																																																																																																																																																																																																																																																																																																																																																																																																																																																																																																																																																																																																																																																							
026																																																																																																																																																																																																																																																																																																																																																																																																																																																																																																																																																																																																																																																																																																																																																																																																																																																																																																																																																																																																																																																																																																							
027																																																																																																																																																																																																																																																																																																																																																																																																																																																																																																																																																																																																																																																																																																																																																																																																																																																																																																																																																																																																																																																																																																							
028																																																																																																																																																																																																																																																																																																																																																																																																																																																																																																																																																																																																																																																																																																																																																																																																																																																																																																																																																																																																																																																																																																							
029																																																																																																																																																																																																																																																																																																																																																																																																																																																																																																																																																																																																																																																																																																																																																																																																																																																																																																																																																																																																																																																																																																							
030																																																																																																																																																																																																																																																																																																																																																																																																																																																																																																																																																																																																																																																																																																																																																																																																																																																																																																																																																																																																																																																																																																							
031																																																																																																																																																																																																																																																																																																																																																																																																																																																																																																																																																																																																																																																																																																																																																																																																																																																																																																																																																																																																																																																																																																							
032																																																																																																																																																																																																																																																																																																																																																																																																																																																																																																																																																																																																																																																																																																																																																																																																																																																																																																																																																																																																																																																																																																							
032c																																																																																																																																																																																																																																																																																																																																																																																																																																																																																																																																																																																																																																																																																																																																																																																																																																																																																																																																																																																																																																																																																																							
PA1A	015	PA2A																																																																																																																																																																																																																																																																																																																																																																																																																																																																																																																																																																																																																																																																																																																																																																																																																																																																																																																																																																																																																																																																																																					
PA3A	020	PA4A																																																																																																																																																																																																																																																																																																																																																																																																																																																																																																																																																																																																																																																																																																																																																																																																																																																																																																																																																																																																																																																																																																					
PA5A	030	PA6A																																																																																																																																																																																																																																																																																																																																																																																																																																																																																																																																																																																																																																																																																																																																																																																																																																																																																																																																																																																																																																																																																																					
040		PA7A																																																																																																																																																																																																																																																																																																																																																																																																																																																																																																																																																																																																																																																																																																																																																																																																																																																																																																																																																																																																																																																																																																					
+12V	+12V																																																																																																																																																																																																																																																																																																																																																																																																																																																																																																																																																																																																																																																																																																																																																																																																																																																																																																																																																																																																																																																																																																						
-12V	-12V																																																																																																																																																																																																																																																																																																																																																																																																																																																																																																																																																																																																																																																																																																																																																																																																																																																																																																																																																																																																																																																																																																						
AGND	AGND																																																																																																																																																																																																																																																																																																																																																																																																																																																																																																																																																																																																																																																																																																																																																																																																																																																																																																																																																																																																																																																																																																						
AGND	AGND																																																																																																																																																																																																																																																																																																																																																																																																																																																																																																																																																																																																																																																																																																																																																																																																																																																																																																																																																																																																																																																																																																						
+35V	+35V																																																																																																																																																																																																																																																																																																																																																																																																																																																																																																																																																																																																																																																																																																																																																																																																																																																																																																																																																																																																																																																																																																						
-35V	-35V																																																																																																																																																																																																																																																																																																																																																																																																																																																																																																																																																																																																																																																																																																																																																																																																																																																																																																																																																																																																																																																																																																						
010																																																																																																																																																																																																																																																																																																																																																																																																																																																																																																																																																																																																																																																																																																																																																																																																																																																																																																																																																																																																																																																																																																							
012																																																																																																																																																																																																																																																																																																																																																																																																																																																																																																																																																																																																																																																																																																																																																																																																																																																																																																																																																																																																																																																																																																							
013																																																																																																																																																																																																																																																																																																																																																																																																																																																																																																																																																																																																																																																																																																																																																																																																																																																																																																																																																																																																																																																																																																							
014																																																																																																																																																																																																																																																																																																																																																																																																																																																																																																																																																																																																																																																																																																																																																																																																																																																																																																																																																																																																																																																																																																							
015																																																																																																																																																																																																																																																																																																																																																																																																																																																																																																																																																																																																																																																																																																																																																																																																																																																																																																																																																																																																																																																																																																							
016																																																																																																																																																																																																																																																																																																																																																																																																																																																																																																																																																																																																																																																																																																																																																																																																																																																																																																																																																																																																																																																																																																							
017																																																																																																																																																																																																																																																																																																																																																																																																																																																																																																																																																																																																																																																																																																																																																																																																																																																																																																																																																																																																																																																																																																							
018																																																																																																																																																																																																																																																																																																																																																																																																																																																																																																																																																																																																																																																																																																																																																																																																																																																																																																																																																																																																																																																																																																							
019																																																																																																																																																																																																																																																																																																																																																																																																																																																																																																																																																																																																																																																																																																																																																																																																																																																																																																																																																																																																																																																																																																							
020																																																																																																																																																																																																																																																																																																																																																																																																																																																																																																																																																																																																																																																																																																																																																																																																																																																																																																																																																																																																																																																																																																							
B6																																																																																																																																																																																																																																																																																																																																																																																																																																																																																																																																																																																																																																																																																																																																																																																																																																																																																																																																																																																																																																																																																																							
B4																																																																																																																																																																																																																																																																																																																																																																																																																																																																																																																																																																																																																																																																																																																																																																																																																																																																																																																																																																																																																																																																																																							
B2																																																																																																																																																																																																																																																																																																																																																																																																																																																																																																																																																																																																																																																																																																																																																																																																																																																																																																																																																																																																																																																																																																							
B0																																																																																																																																																																																																																																																																																																																																																																																																																																																																																																																																																																																																																																																																																																																																																																																																																																																																																																																																																																																																																																																																																																							
025																																																																																																																																																																																																																																																																																																																																																																																																																																																																																																																																																																																																																																																																																																																																																																																																																																																																																																																																																																																																																																																																																																							
026																																																																																																																																																																																																																																																																																																																																																																																																																																																																																																																																																																																																																																																																																																																																																																																																																																																																																																																																																																																																																																																																																																							
027																																																																																																																																																																																																																																																																																																																																																																																																																																																																																																																																																																																																																																																																																																																																																																																																																																																																																																																																																																																																																																																																																																							
028																																																																																																																																																																																																																																																																																																																																																																																																																																																																																																																																																																																																																																																																																																																																																																																																																																																																																																																																																																																																																																																																																																							
029																																																																																																																																																																																																																																																																																																																																																																																																																																																																																																																																																																																																																																																																																																																																																																																																																																																																																																																																																																																																																																																																																																							
030																																																																																																																																																																																																																																																																																																																																																																																																																																																																																																																																																																																																																																																																																																																																																																																																																																																																																																																																																																																																																																																																																																							
031																																																																																																																																																																																																																																																																																																																																																																																																																																																																																																																																																																																																																																																																																																																																																																																																																																																																																																																																																																																																																																																																																																							
032																																																																																																																																																																																																																																																																																																																																																																																																																																																																																																																																																																																																																																																																																																																																																																																																																																																																																																																																																																																																																																																																																																							
032c																																																																																																																																																																																																																																																																																																																																																																																																																																																																																																																																																																																																																																																																																																																																																																																																																																																																																																																																																																																																																																																																																																							
AMP1	015	AMP2																																																																																																																																																																																																																																																																																																																																																																																																																																																																																																																																																																																																																																																																																																																																																																																																																																																																																																																																																																																																																																																																																																					
AMP3	020	AMP4																																																																																																																																																																																																																																																																																																																																																																																																																																																																																																																																																																																																																																																																																																																																																																																																																																																																																																																																																																																																																																																																																																					
TO ECHO	030	FROM ECHO B																																																																																																																																																																																																																																																																																																																																																																																																																																																																																																																																																																																																																																																																																																																																																																																																																																																																																																																																																																																																																																																																																																					
040		FROM ECHO A																																																																																																																																																																																																																																																																																																																																																																																																																																																																																																																																																																																																																																																																																																																																																																																																																																																																																																																																																																																																																																																																																																					
+12V	+12V																																																																																																																																																																																																																																																																																																																																																																																																																																																																																																																																																																																																																																																																																																																																																																																																																																																																																																																																																																																																																																																																																																						
-12V	-12V																																																																																																																																																																																																																																																																																																																																																																																																																																																																																																																																																																																																																																																																																																																																																																																																																																																																																																																																																																																																																																																																																																						
AGND	AGND																																																																																																																																																																																																																																																																																																																																																																																																																																																																																																																																																																																																																																																																																																																																																																																																																																																																																																																																																																																																																																																																																																						
AGND	AGND																																																																																																																																																																																																																																																																																																																																																																																																																																																																																																																																																																																																																																																																																																																																																																																																																																																																																																																																																																																																																																																																																																						
+35V	+35V																																																																																																																																																																																																																																																																																																																																																																																																																																																																																																																																																																																																																																																																																																																																																																																																																																																																																																																																																																																																																																																																																																						
-35V	-35V																																																																																																																																																																																																																																																																																																																																																																																																																																																																																																																																																																																																																																																																																																																																																																																																																																																																																																																																																																																																																																																																																																						
010																																																																																																																																																																																																																																																																																																																																																																																																																																																																																																																																																																																																																																																																																																																																																																																																																																																																																																																																																																																																																																																																																																							
012																																																																																																																																																																																																																																																																																																																																																																																																																																																																																																																																																																																																																																																																																																																																																																																																																																																																																																																																																																																																																																																																																																							
013																																																																																																																																																																																																																																																																																																																																																																																																																																																																																																																																																																																																																																																																																																																																																																																																																																																																																																																																																																																																																																																																																																							
014																																																																																																																																																																																																																																																																																																																																																																																																																																																																																																																																																																																																																																																																																																																																																																																																																																																																																																																																																																																																																																																																																																							
015																																																																																																																																																																																																																																																																																																																																																																																																																																																																																																																																																																																																																																																																																																																																																																																																																																																																																																																																																																																																																																																																																																							
016																																																																																																																																																																																																																																																																																																																																																																																																																																																																																																																																																																																																																																																																																																																																																																																																																																																																																																																																																																																																																																																																																																							
017																																																																																																																																																																																																																																																																																																																																																																																																																																																																																																																																																																																																																																																																																																																																																																																																																																																																																																																																																																																																																																																																																																							
018																																																																																																																																																																																																																																																																																																																																																																																																																																																																																																																																																																																																																																																																																																																																																																																																																																																																																																																																																																																																																																																																																																							
019																																																																																																																																																																																																																																																																																																																																																																																																																																																																																																																																																																																																																																																																																																																																																																																																																																																																																																																																																																																																																																																																																																							
020																																																																																																																																																																																																																																																																																																																																																																																																																																																																																																																																																																																																																																																																																																																																																																																																																																																																																																																																																																																																																																																																																																							
B6																																																																																																																																																																																																																																																																																																																																																																																																																																																																																																																																																																																																																																																																																																																																																																																																																																																																																																																																																																																																																																																																																																							
B4																																																																																																																																																																																																																																																																																																																																																																																																																																																																																																																																																																																																																																																																																																																																																																																																																																																																																																																																																																																																																																																																																																							
B2																																																																																																																																																																																																																																																																																																																																																																																																																																																																																																																																																																																																																																																																																																																																																																																																																																																																																																																																																																																																																																																																																																							
B0																																																																																																																																																																																																																																																																																																																																																																																																																																																																																																																																																																																																																																																																																																																																																																																																																																																																																																																																																																																																																																																																																																							
025																																																																																																																																																																																																																																																																																																																																																																																																																																																																																																																																																																																																																																																																																																																																																																																																																																																																																																																																																																																																																																																																																																							
026																																																																																																																																																																																																																																																																																																																																																																																																																																																																																																																																																																																																																																																																																																																																																																																																																																																																																																																																																																																																																																																																																																							
027																																																																																																																																																																																																																																																																																																																																																																																																																																																																																																																																																																																																																																																																																																																																																																																																																																																																																																																																																																																																																																																																																																							
028																																																																																																																																																																																																																																																																																																																																																																																																																																																																																																																																																																																																																																																																																																																																																																																																																																																																																																																																																																																																																																																																																																							
029																																																																																																																																																																																																																																																																																																																																																																																																																																																																																																																																																																																																																																																																																																																																																																																																																																																																																																																																																																																																																																																																																																							
030																																																																																																																																																																																																																																																																																																																																																																																																																																																																																																																																																																																																																																																																																																																																																																																																																																																																																																																																																																																																																																																																																																							
031																																																																																																																																																																																																																																																																																																																																																																																																																																																																																																																																																																																																																																																																																																																																																																																																																																																																																																																																																																																																																																																																																																							
032																																																																																																																																																																																																																																																																																																																																																																																																																																																																																																																																																																																																																																																																																																																																																																																																																																																																																																																																																																																																																																																																																																							
032c																																																																																																																																																																																																																																																																																																																																																																																																																																																																																																																																																																																																																																																																																																																																																																																																																																																																																																																																																																																																																																																																																																							
AMP3	015	AMP4																																																																																																																																																																																																																																																																																																																																																																																																																																																																																																																																																																																																																																																																																																																																																																																																																																																																																																																																																																																																																																																																																																					
AMP5	020	AMP6																																																																																																																																																																																																																																																																																																																																																																																																																																																																																																																																																																																																																																																																																																																																																																																																																																																																																																																																																																																																																																																																																																					
TO ECHO	030	FROM ECHO B																																																																																																																																																																																																																																																																																																																																																																																																																																																																																																																																																																																																																																																																																																																																																																																																																																																																																																																																																																																																																																																																																																					
040		FROM ECHO A																																																																																																																																																																																																																																																																																																																																																																																																																																																																																																																																																																																																																																																																																																																																																																																																																																																																																																																																																																																																																																																																																																					
+12V	+12V																																																																																																																																																																																																																																																																																																																																																																																																																																																																																																																																																																																																																																																																																																																																																																																																																																																																																																																																																																																																																																																																																																						
-12V	-12V																																																																																																																																																																																																																																																																																																																																																																																																																																																																																																																																																																																																																																																																																																																																																																																																																																																																																																																																																																																																																																																																																																						
AGND	AGND																																																																																																																																																																																																																																																																																																																																																																																																																																																																																																																																																																																																																																																																																																																																																																																																																																																																																																																																																																																																																																																																																																						
AGND	AGND																																																																																																																																																																																																																																																																																																																																																																																																																																																																																																																																																																																																																																																																																																																																																																																																																																																																																																																																																																																																																																																																																																						
+35V	+35V																																																																																																																																																																																																																																																																																																																																																																																																																																																																																																																																																																																																																																																																																																																																																																																																																																																																																																																																																																																																																																																																																																						
-35V	-35V																																																																																																																																																																																																																																																																																																																																																																																																																																																																																																																																																																																																																																																																																																																																																																																																																																																																																																																																																																																																																																																																																																						
010																																																																																																																																																																																																																																																																																																																																																																																																																																																																																																																																																																																																																																																																																																																																																																																																																																																																																																																																																																																																																																																																																																							
012																																																																																																																																																																																																																																																																																																																																																																																																																																																																																																																																																																																																																																																																																																																																																																																																																																																																																																																																																																																																																																																																																																							
013																																																																																																																																																																																																																																																																																																																																																																																																																																																																																																																																																																																																																																																																																																																																																																																																																																																																																																																																																																																																																																																																																																							
014																																																																																																																																																																																																																																																																																																																																																																																																																																																																																																																																																																																																																																																																																																																																																																																																																																																																																																																																																																																																																																																																																																							
015																																																																																																																																																																																																																																																																																																																																																																																																																																																																																																																																																																																																																																																																																																																																																																																																																																																																																																																																																																																																																																																																																																							
016																																																																																																																																																																																																																																																																																																																																																																																																																																																																																																																																																																																																																																																																																																																																																																																																																																																																																																																																																																																																																																																																																																							
017																																																																																																																																																																																																																																																																																																																																																																																																																																																																																																																																																																																																																																																																																																																																																																																																																																																																																																																																																																																																																																																																																																							
018																																																																																																																																																																																																																																																																																																																																																																																																																																																																																																																																																																																																																																																																																																																																																																																																																																																																																																																																																																																																																																																																																																							
019																																																																																																																																																																																																																																																																																																																																																																																																																																																																																																																																																																																																																																																																																																																																																																																																																																																																																																																																																																																																																																																																																																							
020																																																																																																																																																																																																																																																																																																																																																																																																																																																																																																																																																																																																																																																																																																																																																																																																																																																																																																																																																																																																																																																																																																							
B6																																																																																																																																																																																																																																																																																																																																																																																																																																																																																																																																																																																																																																																																																																																																																																																																																																																																																																																																																																																																																																																																																																							
B4																																																																																																																																																																																																																																																																																																																																																																																																																																																																																																																																																																																																																																																																																																																																																																																																																																																																																																																																																																																																																																																																																																							
B2																																																																																																																																																																																																																																																																																																																																																																																																																																																																																																																																																																																																																																																																																																																																																																																																																																																																																																																																																																																																																																																																																																							
B0																																																																																																																																																																																																																																																																																																																																																																																																																																																																																																																																																																																																																																																																																																																																																																																																																																																																																																																																																																																																																																																																																																							
025																																																																																																																																																																																																																																																																																																																																																																																																																																																																																																																																																																																																																																																																																																																																																																																																																																																																																																																																																																																																																																																																																																							
026																																																																																																																																																																																																																																																																																																																																																																																																																																																																																																																																																																																																																																																																																																																																																																																																																																																																																																																																																																																																																																																																																																							
027																																																																																																																																																																																																																																																																																																																																																																																																																																																																																																																																																																																																																																																																																																																																																																																																																																																																																																																																																																																																																																																																																																							
028																																																																																																																																																																																																																																																																																																																																																																																																																																																																																																																																																																																																																																																																																																																																																																																																																																																																																																																																																																																																																																																																																																							
029																																																																																																																																																																																																																																																																																																																																																																																																																																																																																																																																																																																																																																																																																																																																																																																																																																																																																																																																																																																																																																																																																																							
030																																																																																																																																																																																																																																																																																																																																																																																																																																																																																																																																																																																																																																																																																																																																																																																																																																																																																																																																																																																																																																																																																																							
031																																																																																																																																																																																																																																																																																																																																																																																																																																																																																																																																																																																																																																																																																																																																																																																																																																																																																																																																																																																																																																																																																																							
032																																																																																																																																																																																																																																																																																																																																																																																																																																																																																																																																																																																																																																																																																																																																																																																																																																																																																																																																																																																																																																																																																																							
032c																																																																																																																																																																																																																																																																																																																																																																																																																																																																																																																																																																																																																																																																																																																																																																																																																																																																																																																																																																																																																																																																																																							
AMP1	015	AMP2																																																																																																																																																																																																																																																																																																																																																																																																																																																																																																																																																																																																																																																																																																																																																																																																																																																																																																																																																																																																																																																																																																					
AMP3	020	AMP4																																																																																																																																																																																																																																																																																																																																																																																																																																																																																																																																																																																																																																																																																																																																																																																																																																																																																																																																																																																																																																																																																																					
AMP5	030	AMP6																																																																																																																																																																																																																																																																																																																																																																																																																																																																																																																																																																																																																																																																																																																																																																																																																																																																																																																																																																																																																																																																																																					
FROM ECHO A	040	FROM ECHO B																																																																																																																																																																																																																																																																																																																																																																																																																																																																																																																																																																																																																																																																																																																																																																																																																																																																																																																																																																																																																																																																																																					
+12V	+12V																																																																																																																																																																																																																																																																																																																																																																																																																																																																																																																																																																																																																																																																																																																																																																																																																																																																																																																																																																																																																																																																																																						
-12V	-12V																																																																																																																																																																																																																																																																																																																																																																																																																																																																																																																																																																																																																																																																																																																																																																																																																																																																																																																																																																																																																																																																																																						
AGND	AGND																																																																																																																																																																																																																																																																																																																																																																																																																																																																																																																																																																																																																																																																																																																																																																																																																																																																																																																																																																																																																																																																																																						
AGND	AGND																																																																																																																																																																																																																																																																																																																																																																																																																																																																																																																																																																																																																																																																																																																																																																																																																																																																																																																																																																																																																																																																																																						
+35V	+35V																																																																																																																																																																																																																																																																																																																																																																																																																																																																																																																																																																																																																																																																																																																																																																																																																																																																																																																																																																																																																																																																																																						
-35V	-35V																																																																																																																																																																																																																																																																																																																																																																																																																																																																																																																																																																																																																																																																																																																																																																																																																																																																																																																																																																																																																																																																																																						
010																																																																																																																																																																																																																																																																																																																																																																																																																																																																																																																																																																																																																																																																																																																																																																																																																																																																																																																																																																																																																																																																																																							
012																																																																																																																																																																																																																																																																																																																																																																																																																																																																																																																																																																																																																																																																																																																																																																																																																																																																																																																																																																																																																																																																																																							
013																																																																																																																																																																																																																																																																																																																																																																																																																																																																																																																																																																																																																																																																																																																																																																																																																																																																																																																																																																																																																																																																																																							
014																																																																																																																																																																																																																																																																																																																																																																																																																																																																																																																																																																																																																																																																																																																																																																																																																																																																																																																																																																																																																																																																																																							
015																																																																																																																																																																																																																																																																																																																																																																																																																																																																																																																																																																																																																																																																																																																																																																																																																																																																																																																																																																																																																																																																																																							
016																																																																																																																																																																																																																																																																																																																																																																																																																																																																																																																																																																																																																																																																																																																																																																																																																																																																																																																																																																																																																																																																																																							
017																																																																																																																																																																																																																																																																																																																																																																																																																																																																																																																																																																																																																																																																																																																																																																																																																																																																																																																																																																																																																																																																																																							
018																																																																																																																																																																																																																																																																																																																																																																																																																																																																																																																																																																																																																																																																																																																																																																																																																																																																																																																																																																																																																																																																																																							
019																																																																																																																																																																																																																																																																																																																																																																																																																																																																																																																																																																																																																																																																																																																																																																																																																																																																																																																																																																																																																																																																																																							
020																																																																																																																																																																																																																																																																																																																																																																																																																																																																																																																																																																																																																																																																																																																																																																																																																																																																																																																																																																																																																																																																																																							
021																																																																																																																																																																																																																																																																																																																																																																																																																																																																																																																																																																																																																																																																																																																																																																																																																																																																																																																																																																																																																																																																																																							
022																																																																																																																																																																																																																																																																																																																																																																																																																																																																																																																																																																																																																																																																																																																																																																																																																																																																																																																																																																																																																																																																																																							
023																																																																																																																																																																																																																																																																																																																																																																																																																																																																																																																																																																																																																																																																																																																																																																																																																																																																																																																																																																																																																																																																																																							
024																																																																																																																																																																																																																																																																																																																																																																																																																																																																																																																																																																																																																																																																																																																																																																																																																																																																																																																																																																																																																																																																																																							
025																																																																																																																																																																																																																																																																																																																																																																																																																																																																																																																																																																																																																																																																																																																																																																																																																																																																																																																																																																																																																																																																																																							
026																																																																																																																																																																																																																																																																																																																																																																																																																																																																																																																																																																																																																																																																																																																																																																																																																																																																																																																																																																																																																																																																																																							
027																																																																																																																																																																																																																																																																																																																																																																																																																																																																																																																																																																																																																																																																																																																																																																																																																																																																																																																																																																																																																																																																																																							
028																																																																																																																																																																																																																																																																																																																																																																																																																																																																																																																																																																																																																																																																																																																																																																																																																																																																																																																																																																																																																																																																																																							
029																																																																																																																																																																																																																																																																																																																																																																																																																																																																																																																																																																																																																																																																																																																																																																																																																																																																																																																																																																																																																																																																																																							
030																																																																																																																																																																																																																																																																																																																																																																																																																																																																																																																																																																																																																																																																																																																																																																																																																																																																																																																																																																																																																																																																																																							
031																																																																																																																																																																																																																																																																																																																																																																																																																																																																																																																																																																																																																																																																																																																																																																																																																																																																																																																																																																																																																																																																																																							
032																																																																																																																																																																																																																																																																																																																																																																																																																																																																																																																																																																																																																																																																																																																																																																																																																																																																																																																																																																																																																																																																																																							
032c																																																																																																																																																																																																																																																																																																																																																																																																																																																																																																																																																																																																																																																																																																																																																																																																																																																																																																																																																																																																																																																																																																							

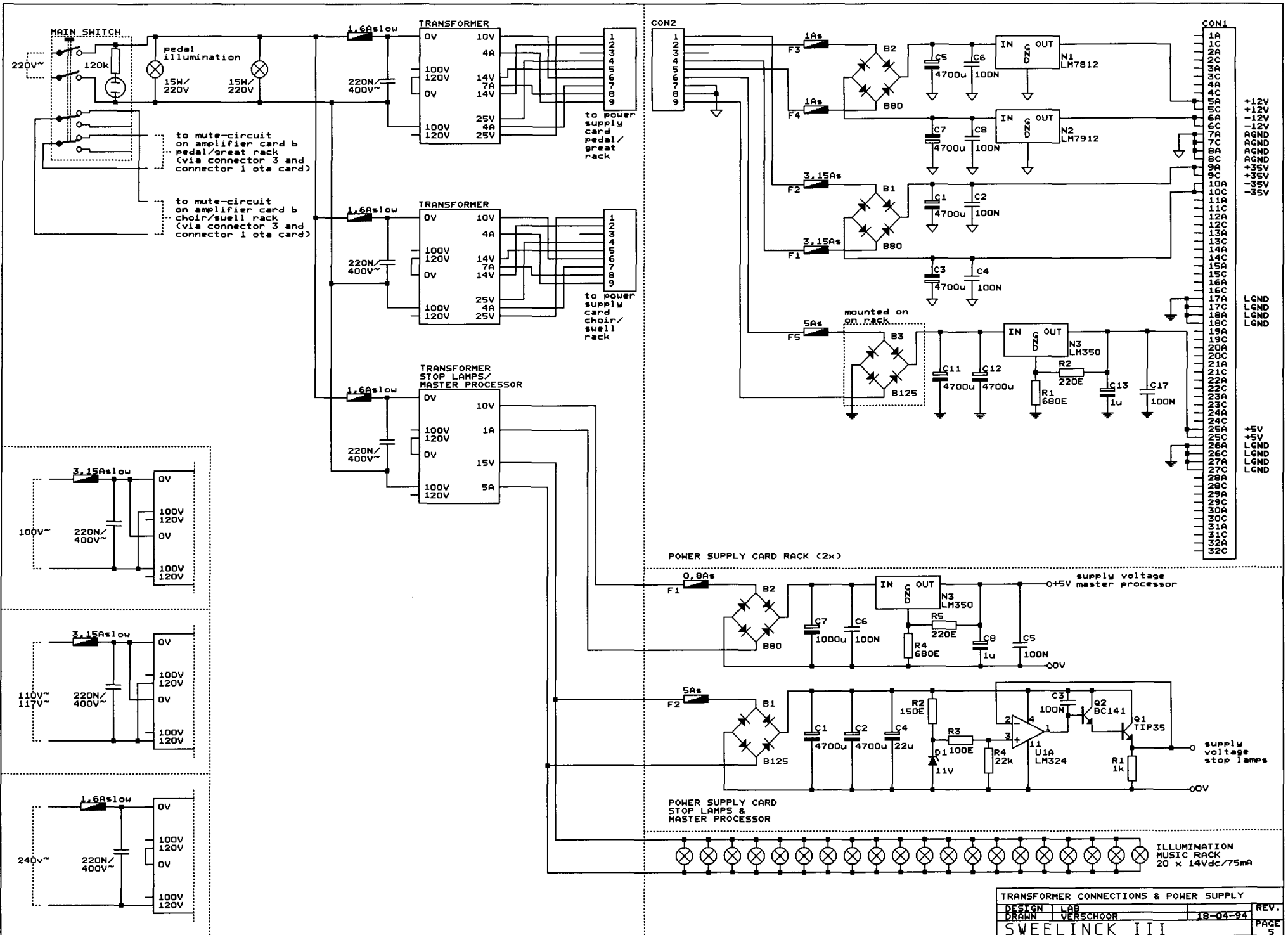

TRANSFORMER CONNECTIONS & POWER SUPPLY			
DESIGN	LAB		REV.
DRAWN	VERSCHOOR	18-04-94	PAGE
SWEELINCK III			5

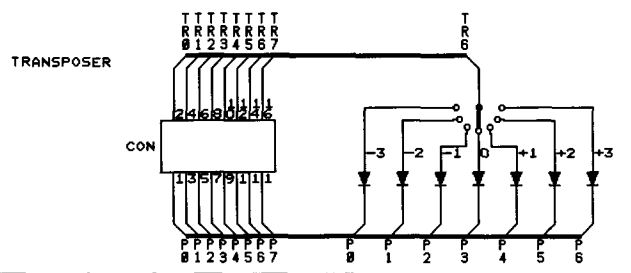
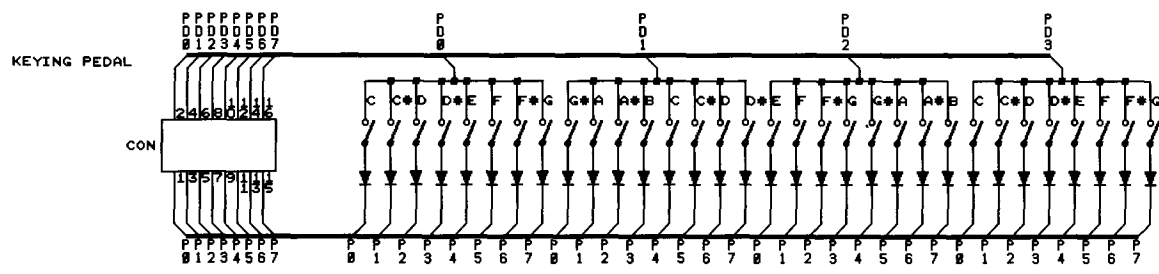
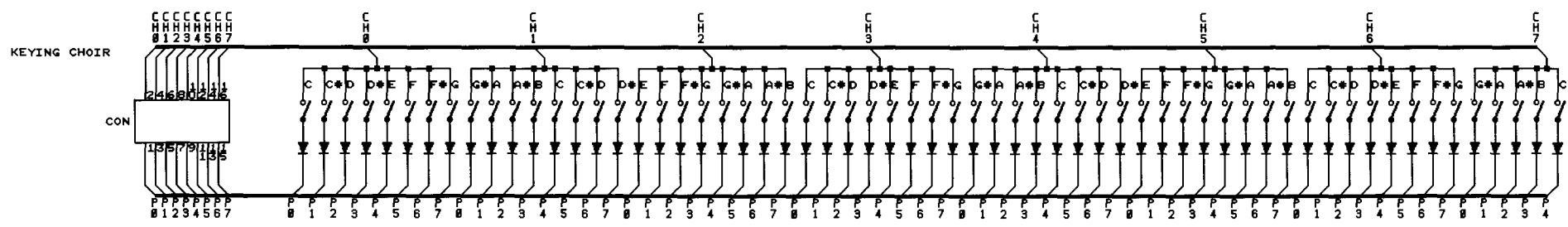
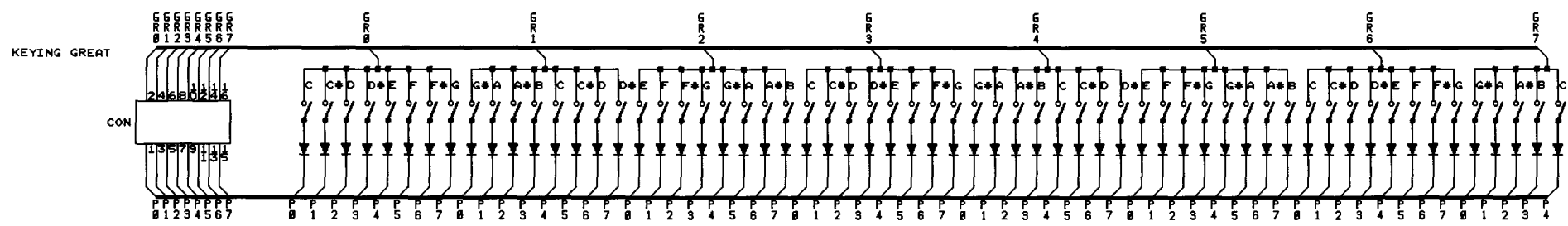
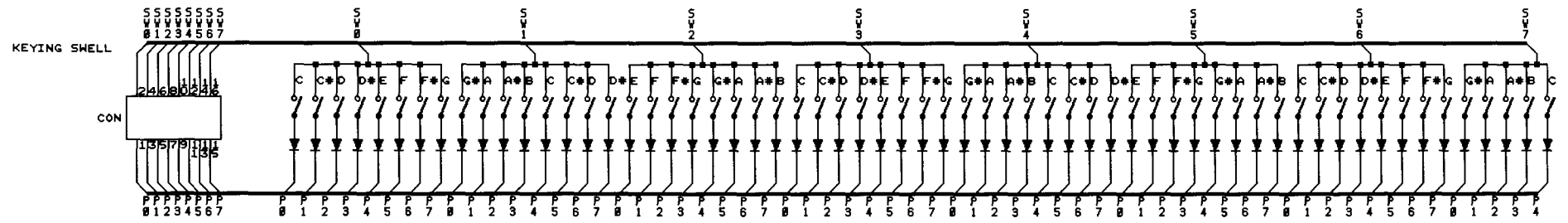

ALL CONNECTORS: TO MASTER PROCESSOR
 ALL DIODES: 1N4148

SCANNING KEYING & TRANSPOSER			
DESIGN	LAB		REV.
DRAWN	VERSCHOOR	18-04-94	PAGE
SWEELINCK III			6

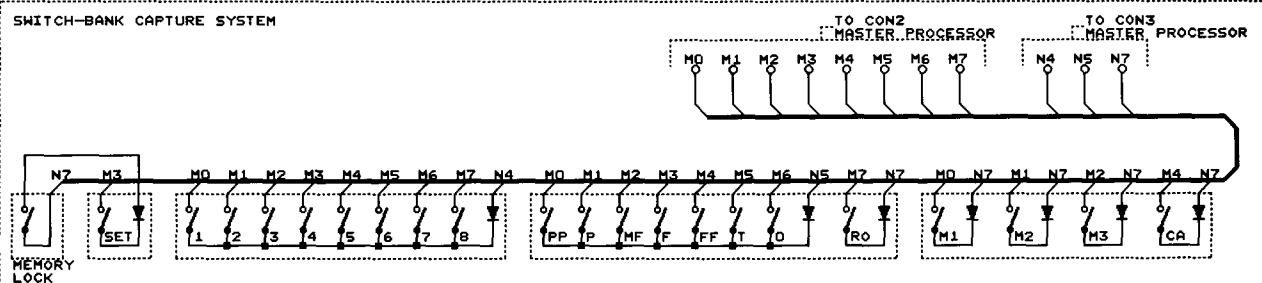
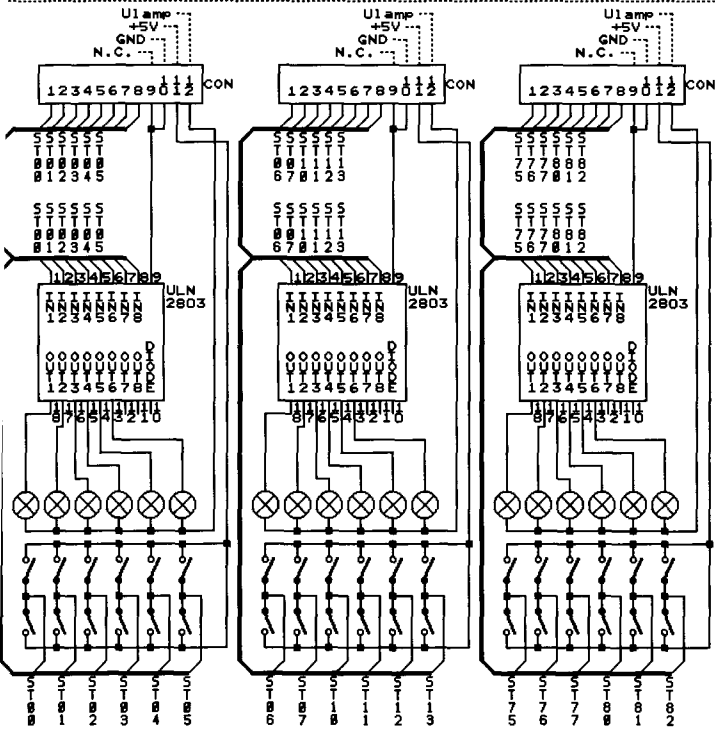
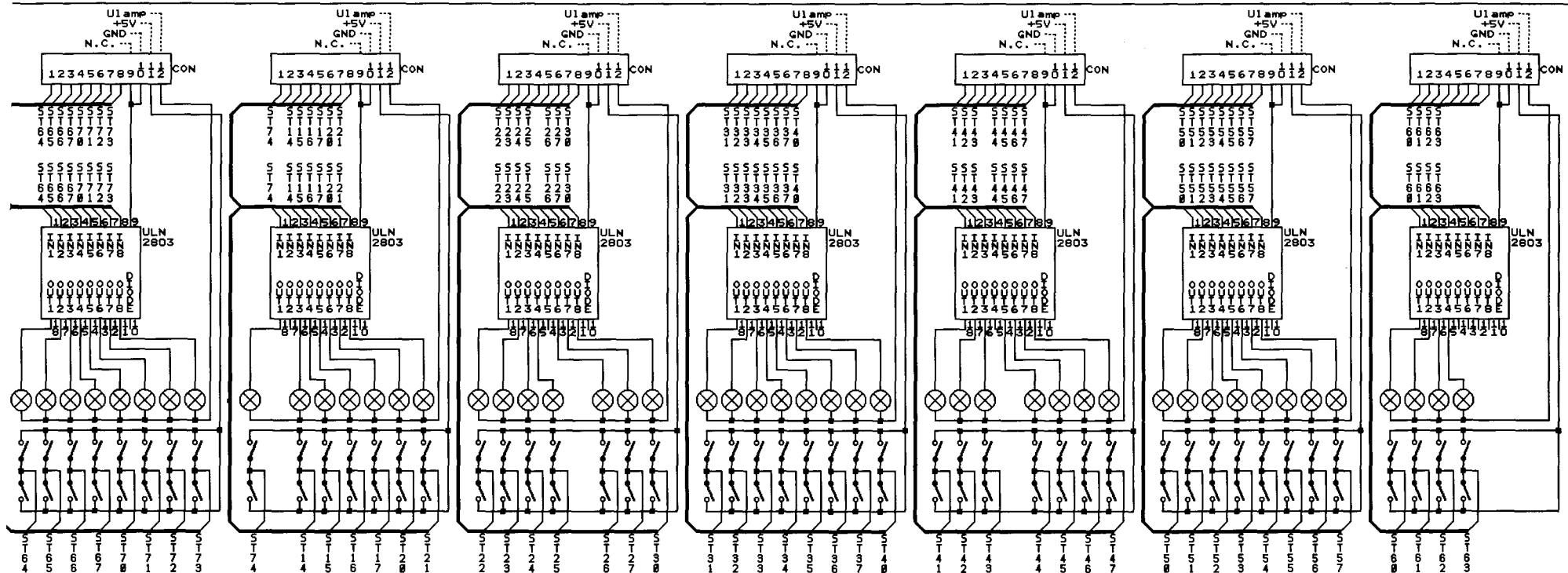

STOPLIST

PEDAL	CHOIR	GREAT	SWELL
ST00 = DOUBLE BASS 16'	ST14 = LIEBL. GEDECKT 16'	ST26 = BOURDON 16'	ST44 = QUINTATON 16'
ST01 = SUBBASS 16'	ST15 = BOURDON 8'	ST27 = OPEN DIAPASON 8'	ST45 = OPEN DIAPASON 8'
ST02 = OCTAVE 8'	ST16 = OCTAVE 4'	ST30 = GAMBA 8'	ST46 = VIOLA 8'
ST03 = GEDACKT 8'	ST17 = OPEN FLUTE 4'	ST31 = ROHRFLUTE 8'	ST47 = CELESTE 8'
ST04 = CHORALBASS 4'	ST20 = NAZARD 2 2/3'	ST32 = OCTAVE 4'	ST50 = STOPPED FLUTE 8'
ST05 = BASSFLUTE 4'	ST21 = CONICAL FLUTE 2'	ST33 = OPEN FLUTE 4'	ST51 = OCTAVE 4'
ST06 = OPEN FLUTE 2'	ST22 = TIERCE 1 3/5'	ST34 = TWELFTH 2 2/3'	ST52 = ROHRFLUTE 4'
ST07 = MIXTURE III	ST23 = STIFFLUITE 1'	ST35 = SUPEROCTAVE 2'	ST53 = FLUTE TWELFTH 2 2/3'
ST10 = BOMBARDE 32'	ST24 = CYMBAL II-III	ST36 = CONICAL FLUTE 2'	ST54 = WALDFLUTE 2'
ST11 = CONTRA TRUMPET 16'	ST25 = CLARINET 8'	ST37 = CORNET IV	ST55 = NAZARD 1 1/3'
ST12 = TRUMPET 8'		ST40 = MIXTURE V-VII	ST56 = OCTAVE 1'
ST13 = CLARION 4'		ST41 = SCHARF III-V	ST57 = SESQUIALTER II
		ST42 = CONTRA TRUMPET 16'	ST60 = RAUSCHEPFEIFE III-V
		ST43 = TRUMPET 8'	ST61 = FAGOTTO 16'
			ST62 = CROMORNE 8'
			ST63 = VOX HUMANA 8'

ALL CONNECTORS: TO MASTER PROCESSOR
 ALL STOPLAMPS: 14Vdc/75mA

STOP-BANK & SWITCH-BANK CAPTURE SYSTEM	REV.
DESIGN LAB	18-04-94
DRAWN VERSCHOOR	PAGE 7
SWEELINCK III	

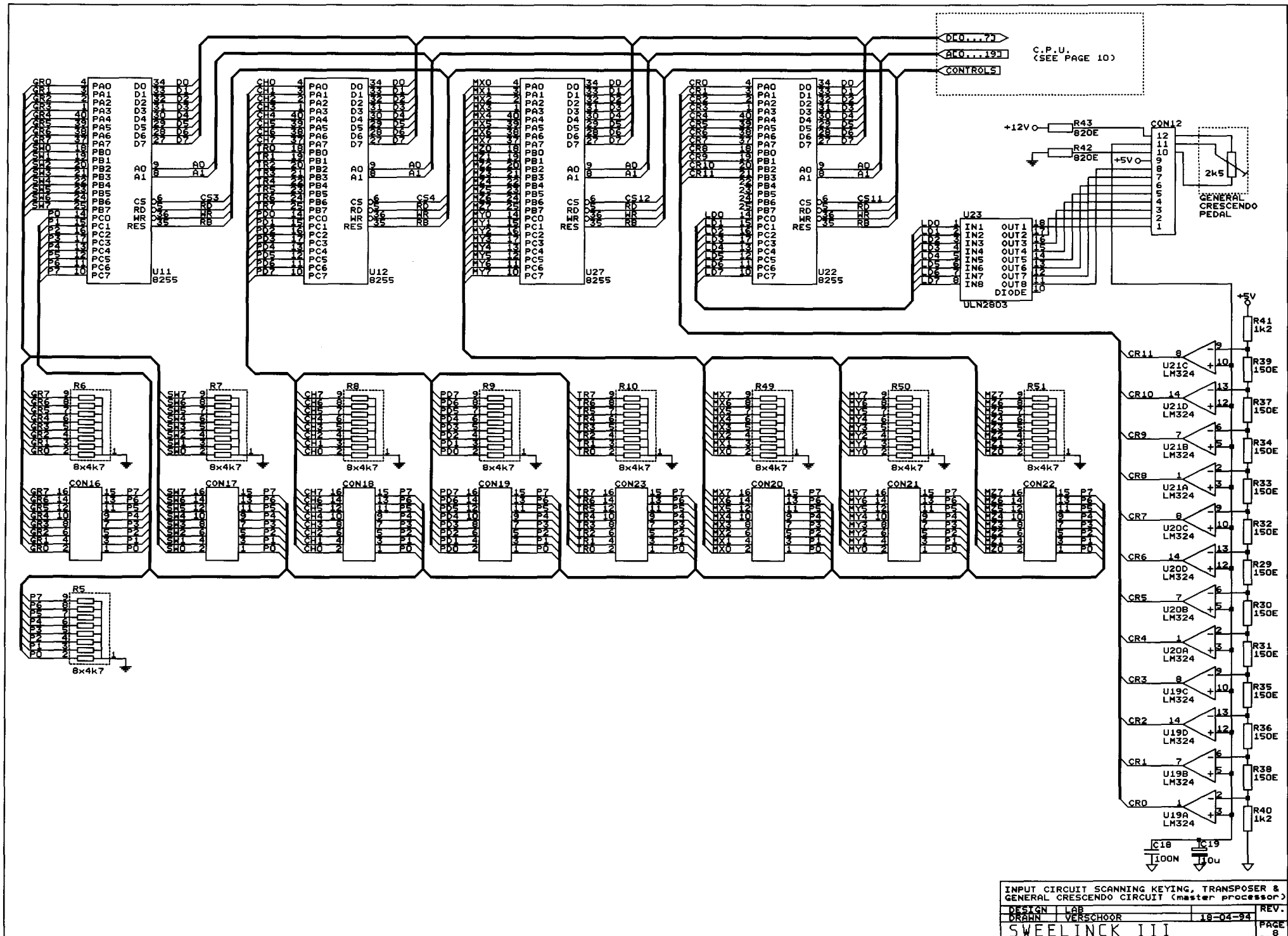

INPUT CIRCUIT SCANNING KEYING, TRANSPOSER & GENERAL CRESCENDO CIRCUIT (master processor)

DESIGN	LAB	REV.
DRAHN	VERSCHOOR	18-04-94
SWEELINCK III		PAGE 8

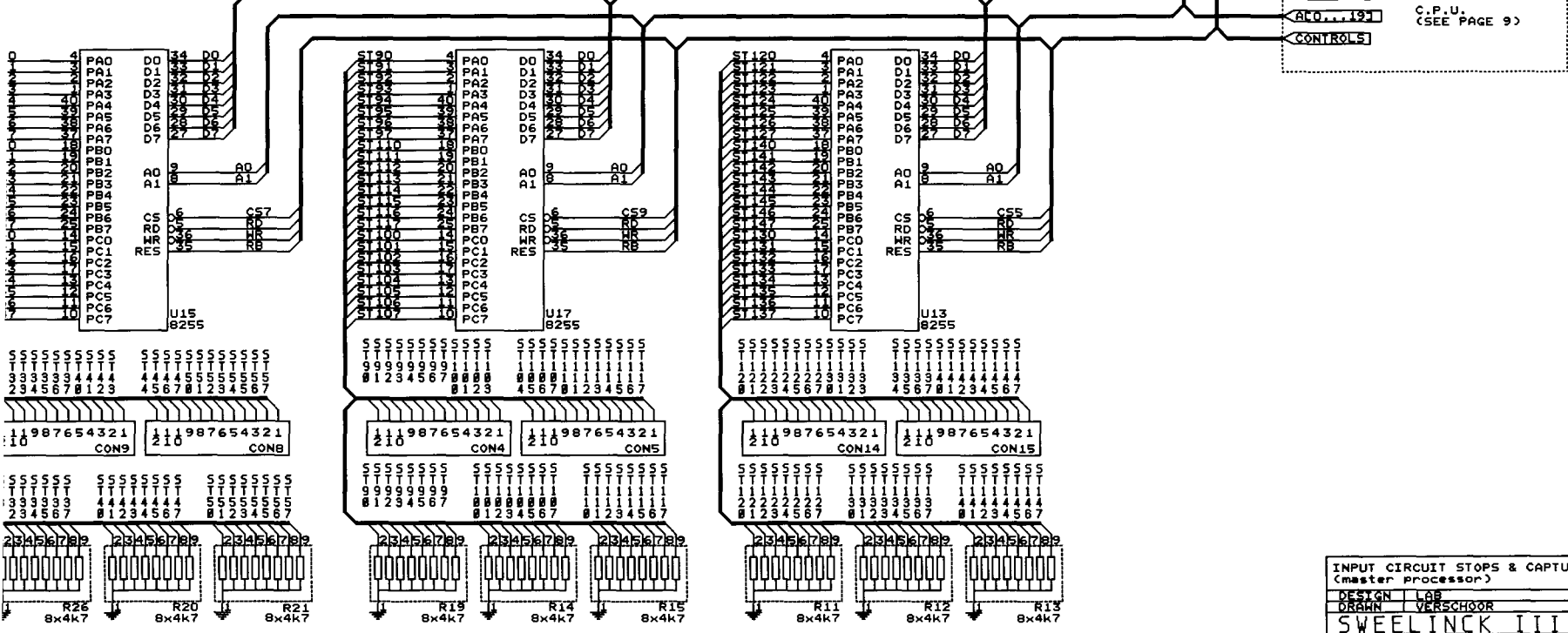
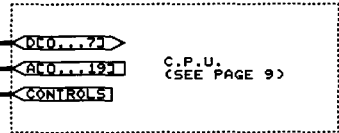
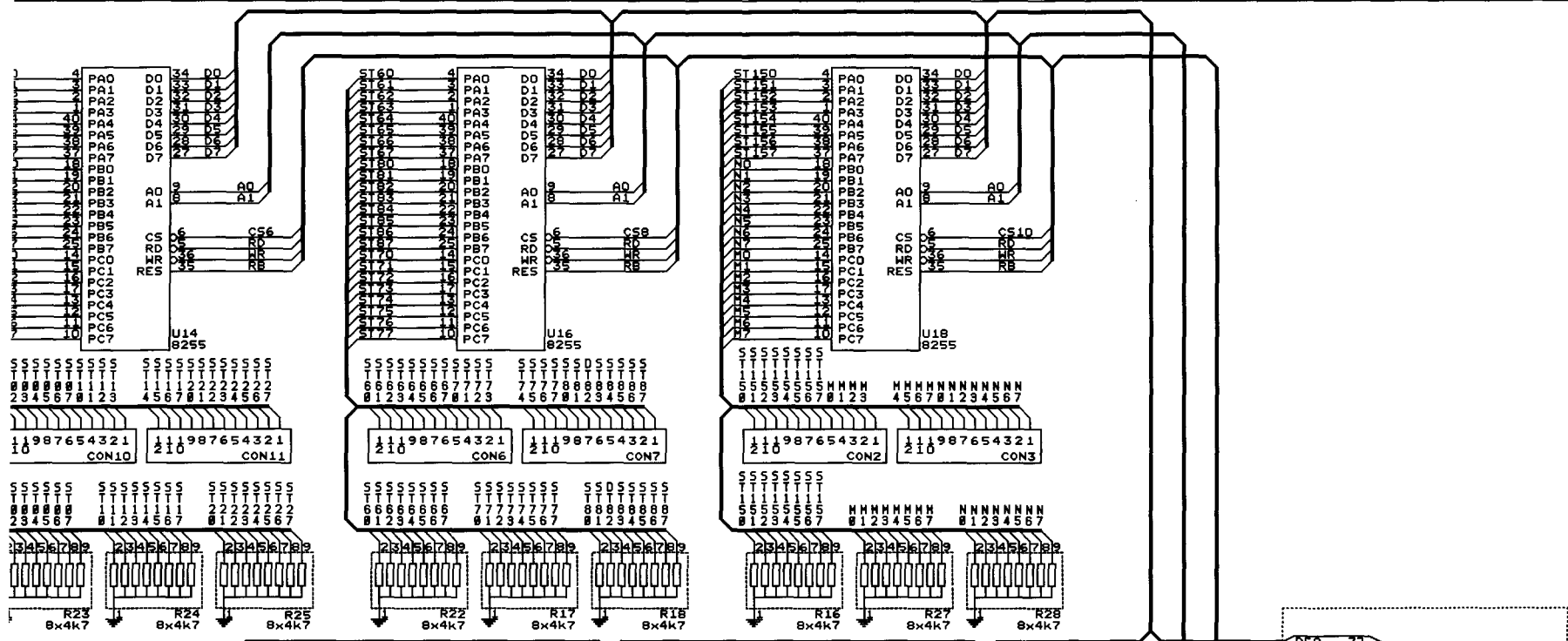

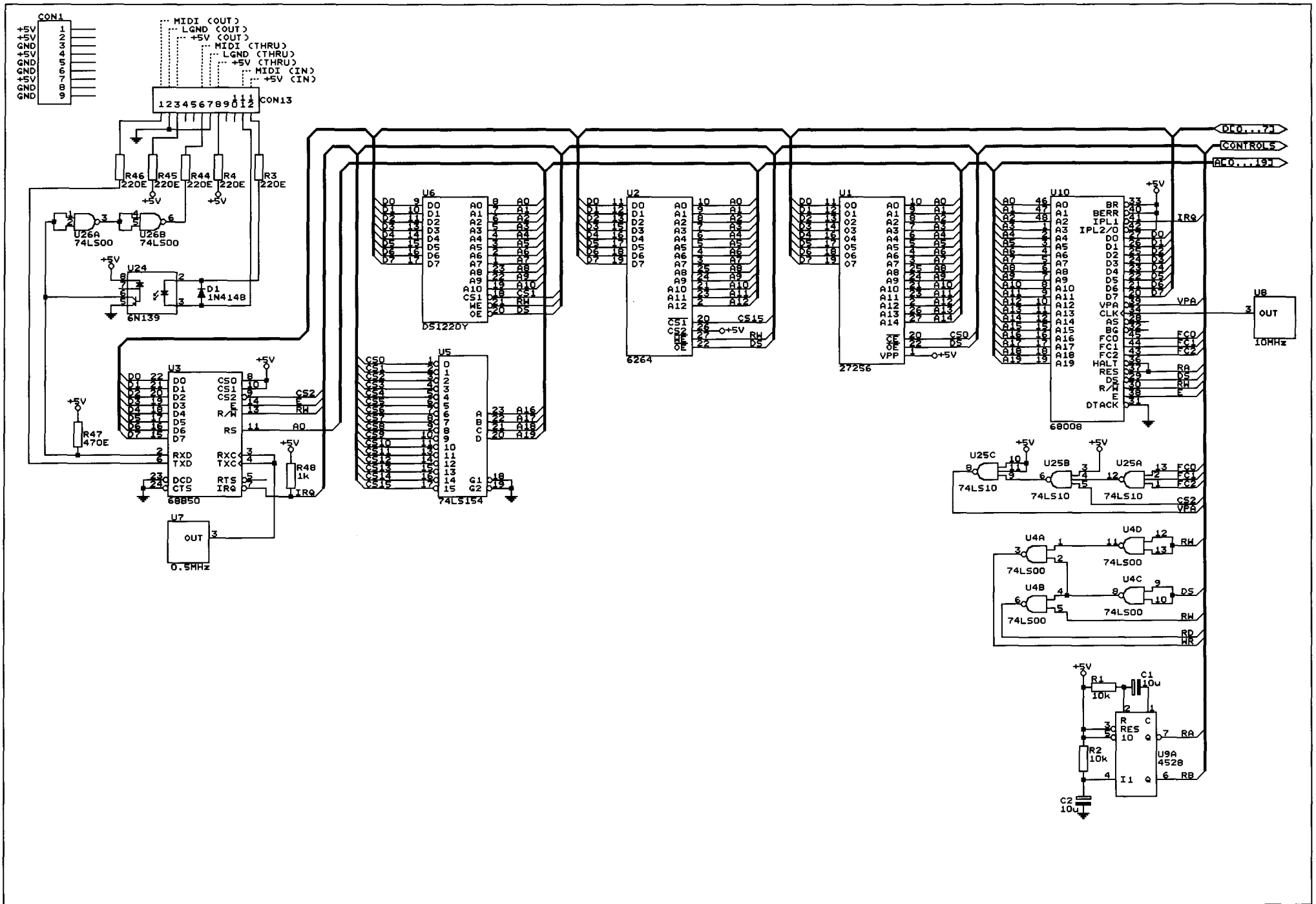

C.P.U. (master processor)			
DESIGN	LAB		REV.
DRAWN	VERSCHOOR	18-04-94	PAGE
SWEELINCK III			10

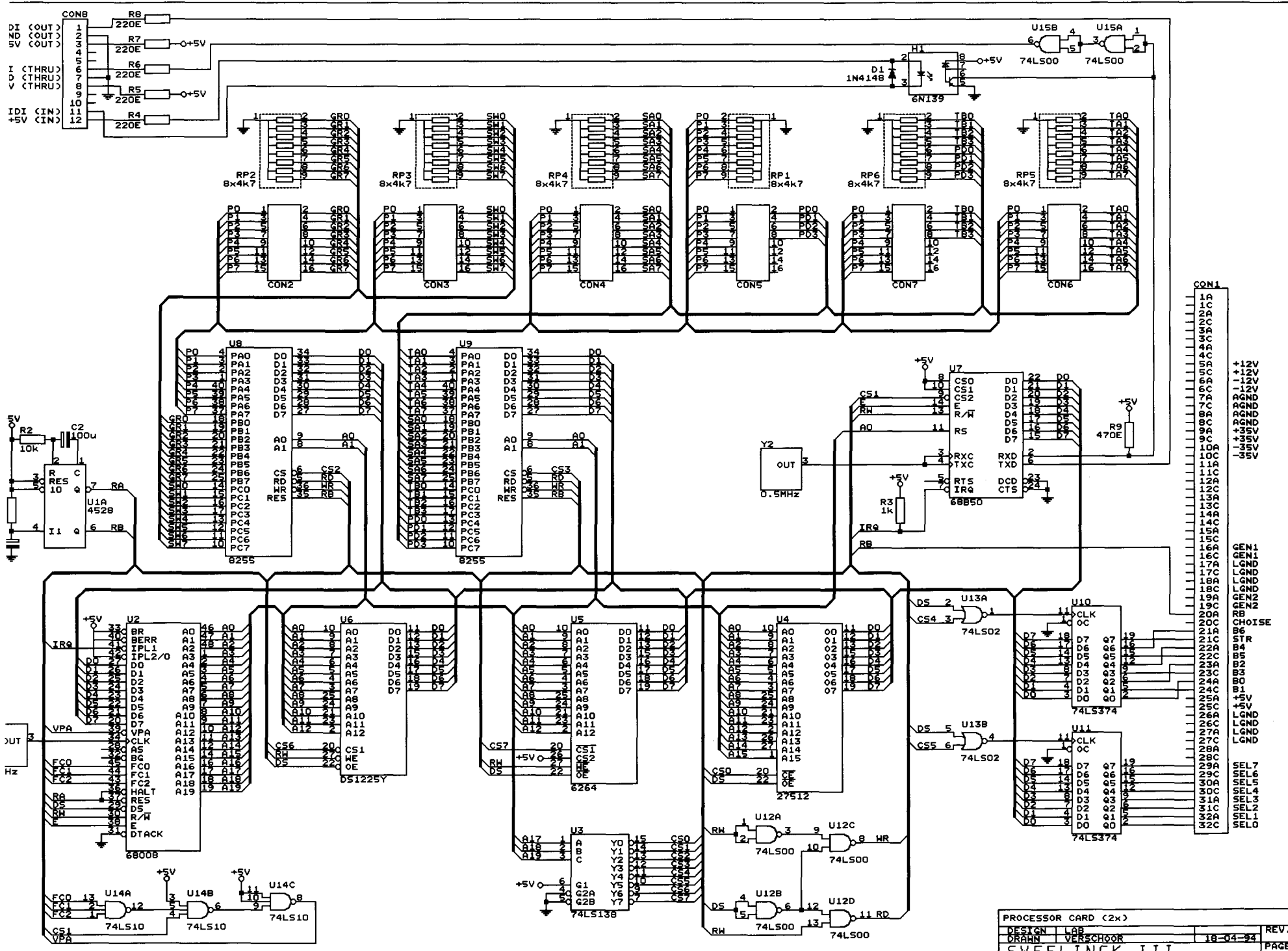

- 1A
- 1C
- 2A
- 2C
- 3C
- 4A
- 4C
- 5A
- 5C
- 6A
- 6C
- 7A
- 7C
- 8A
- 8C
- 9A
- 9C
- 10A
- 10C
- 11A
- 11C
- 12A
- 12C
- 13A
- 13C
- 14A
- 14C
- 15A
- 15C
- 16A
- 16C
- 17A
- 17C
- 18A
- 18C
- 19A
- 19C
- 20A
- 20C
- 21A
- 21C
- 22A
- 22C
- 23A
- 23C
- 24A
- 24C
- 25A
- 25C
- 26A
- 26C
- 27A
- 27C
- 28A
- 28C
- 29A
- 29C
- 30A
- 30C
- 31A
- 31C
- 32A
- 32C
- GEN1
- GEN1
- LGND
- LGND
- LGND
- GEN2
- GEN2
- RB
- CHOISE
- B7
- B6
- B5
- B4
- B3
- B2
- B1
- +5V
- LGND
- LGND
- LGND
- SEL7
- SEL6
- SEL5
- SEL4
- SEL3
- SEL2
- SEL1
- SEL0

PROCESSOR CARD (2x)			
DESIGN	LAB		REV.
DRAWN	VERSCHOOR	18-04-84	PAGE
SWEELINK III			11

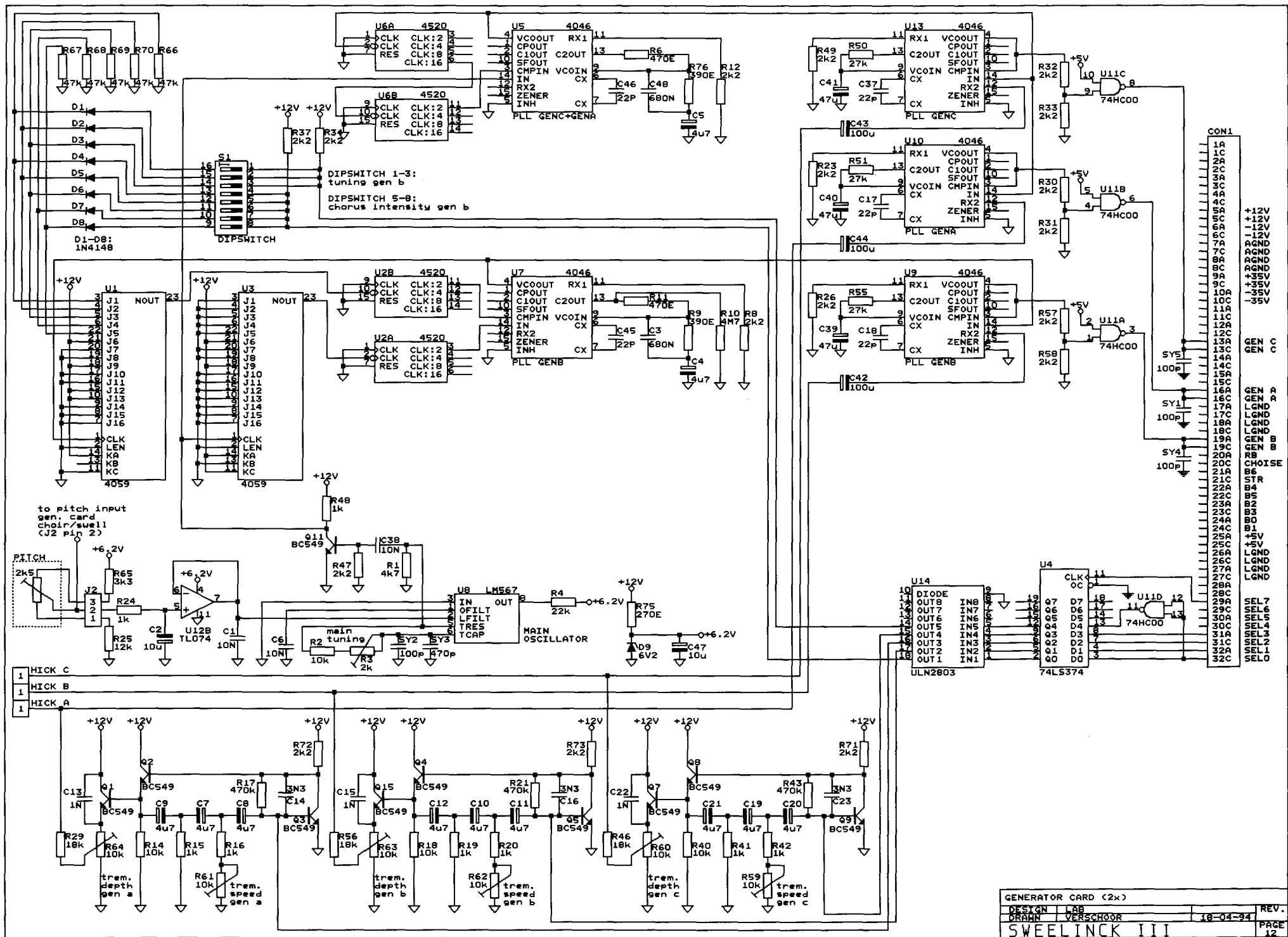

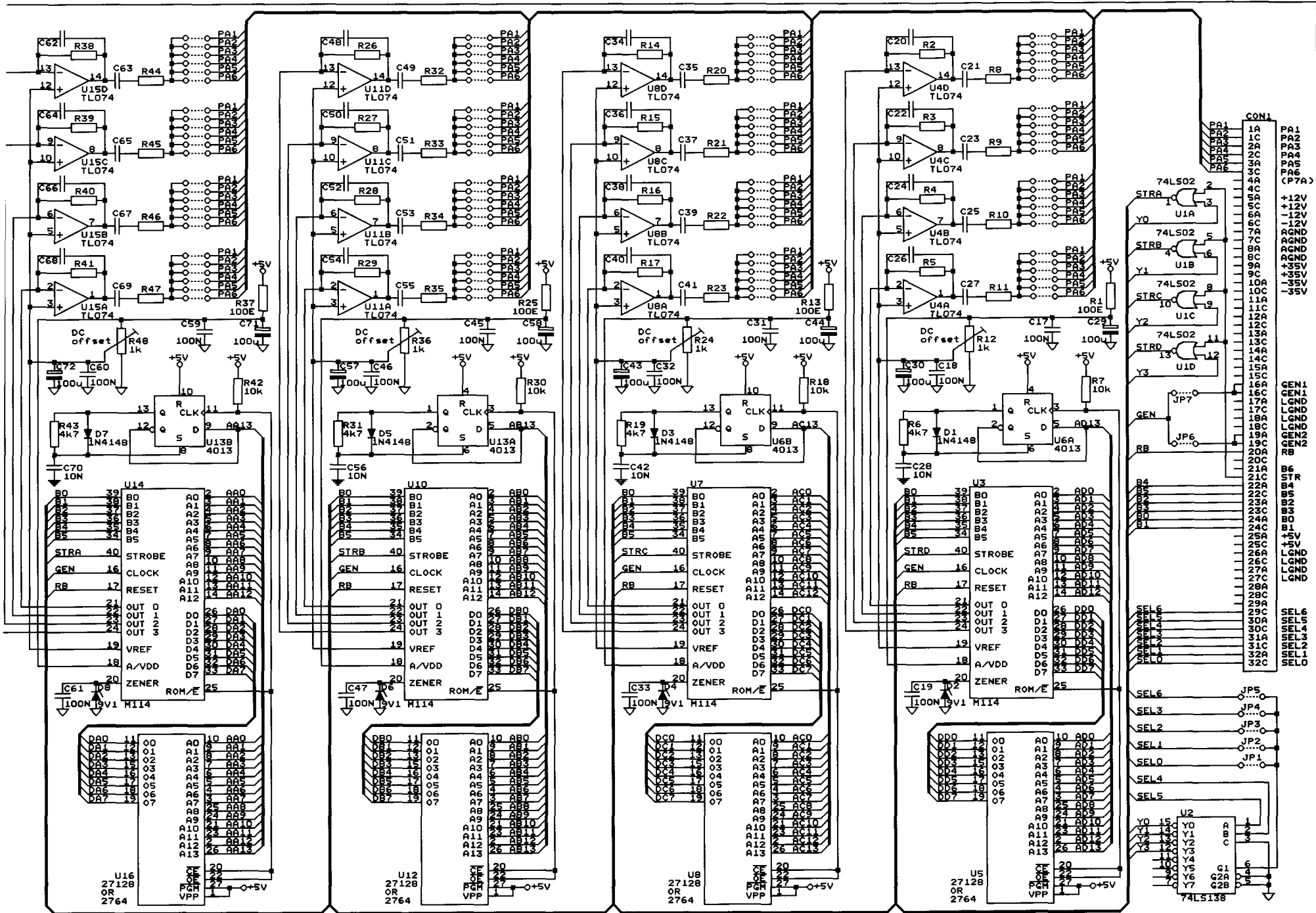

NOTE: IF FOR U5, U8, U12 OR U16 A 2764 EPROM IS PLACED INSTEAD OF A 27128 EPROM, THE 1/2 4013 (U6 AND U13) USED FOR SWITCHING THE UPPER 8K ROM AND THE LOWER 8K ROM, IS NOT NECESSARY.

VOICE CARD (10x)			
DESIGN	LAB		REV.
DRAHN	VERSCHOOR	18-04-94	PAGE
SWEELINK III			13

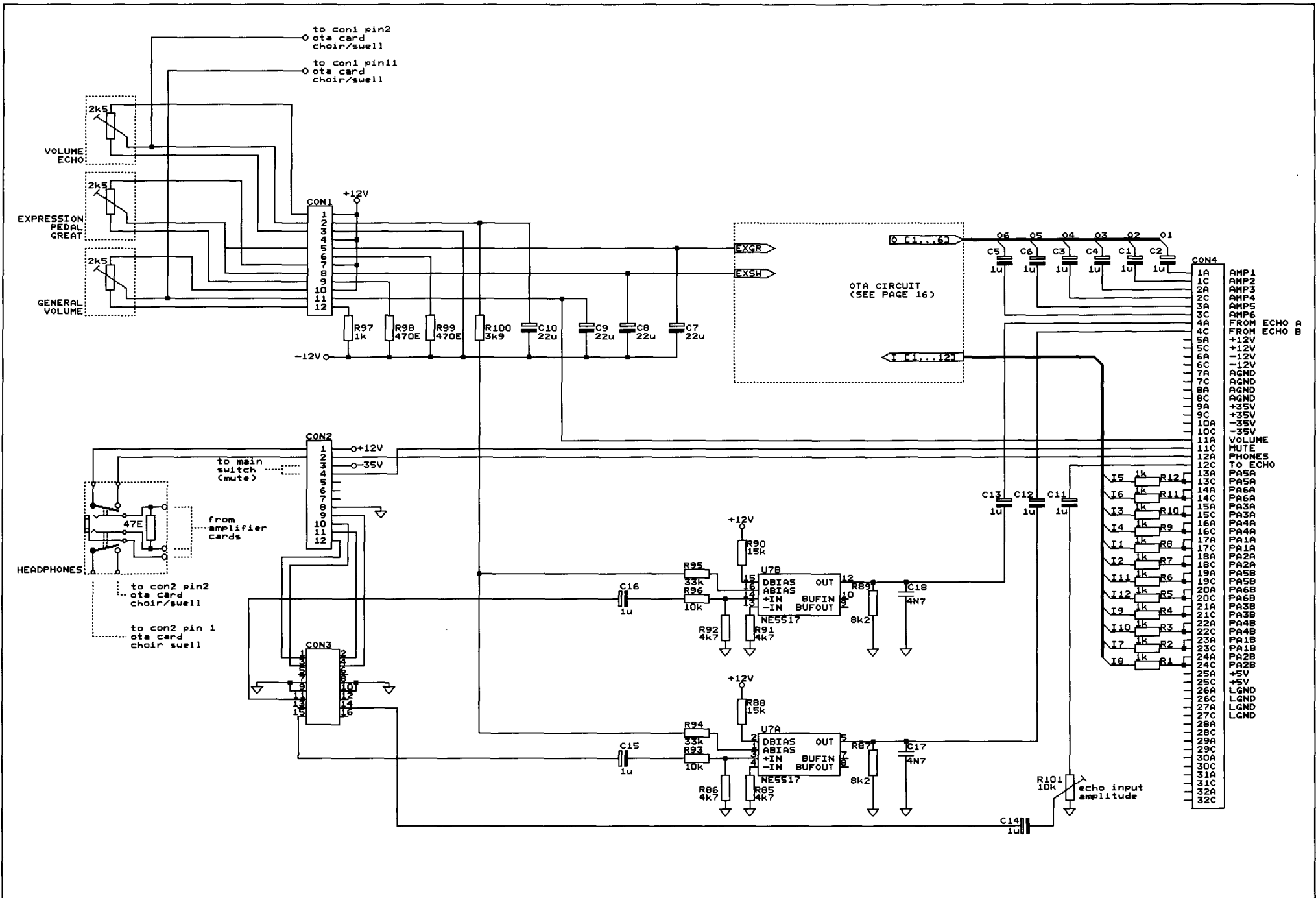

VOLUME CONTROLS; HEADPHONES CONNECTIONS & ECHO INTERFACE (ota card pedal/great)

DESIGN	LAB	REV.
DRAWN	VERSCHOOR	18-04-94
SWEELINCK III		PAGE 14

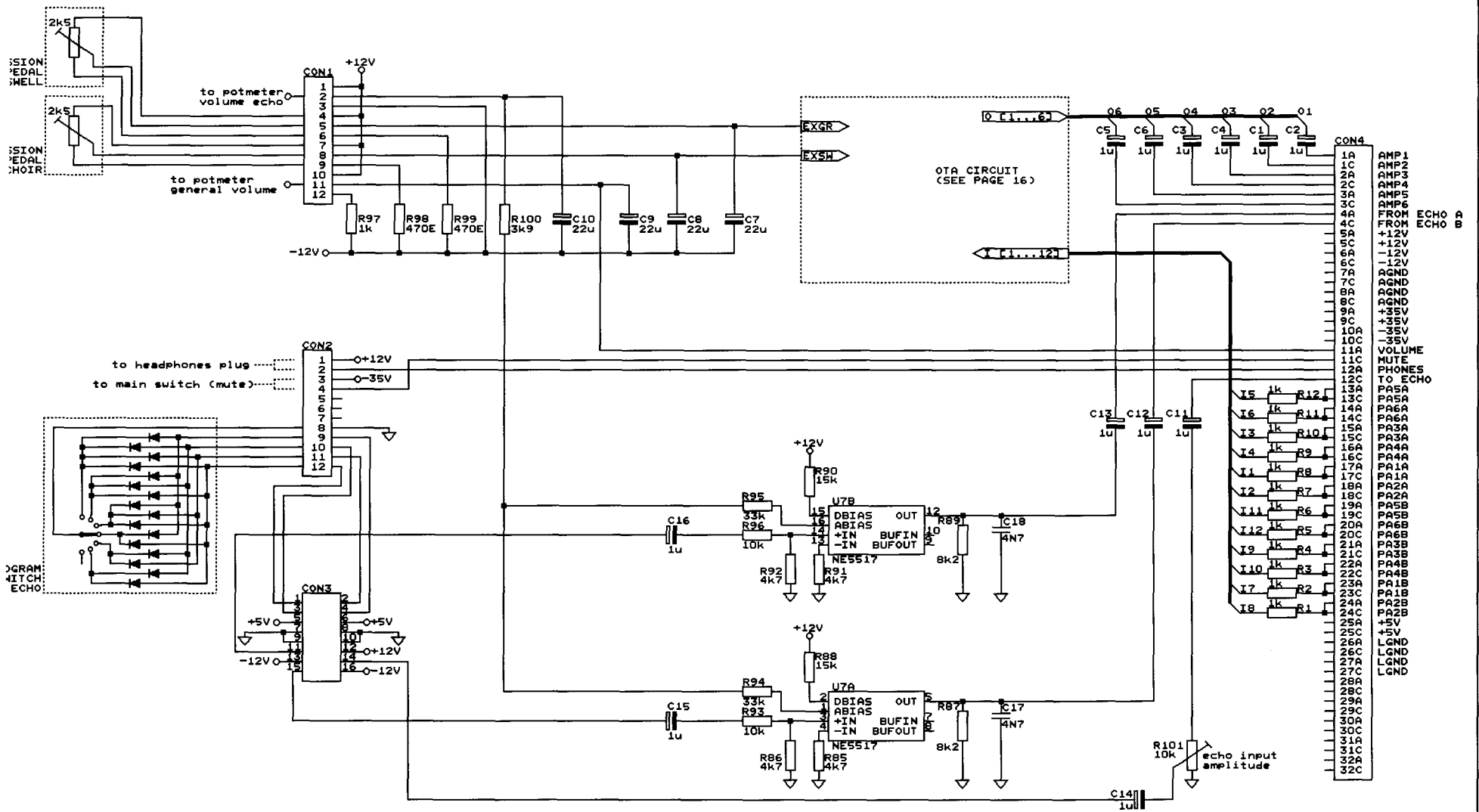

VOLUME CONTROLS; HEADPHONES CONNECTIONS & ECHO INTERFACE (ota card choir/swell)			
DESIGN	LOB		REV.
DRAWN	VERSCHOOR	18-04-94	PAGE 15
SWEELINCK III			

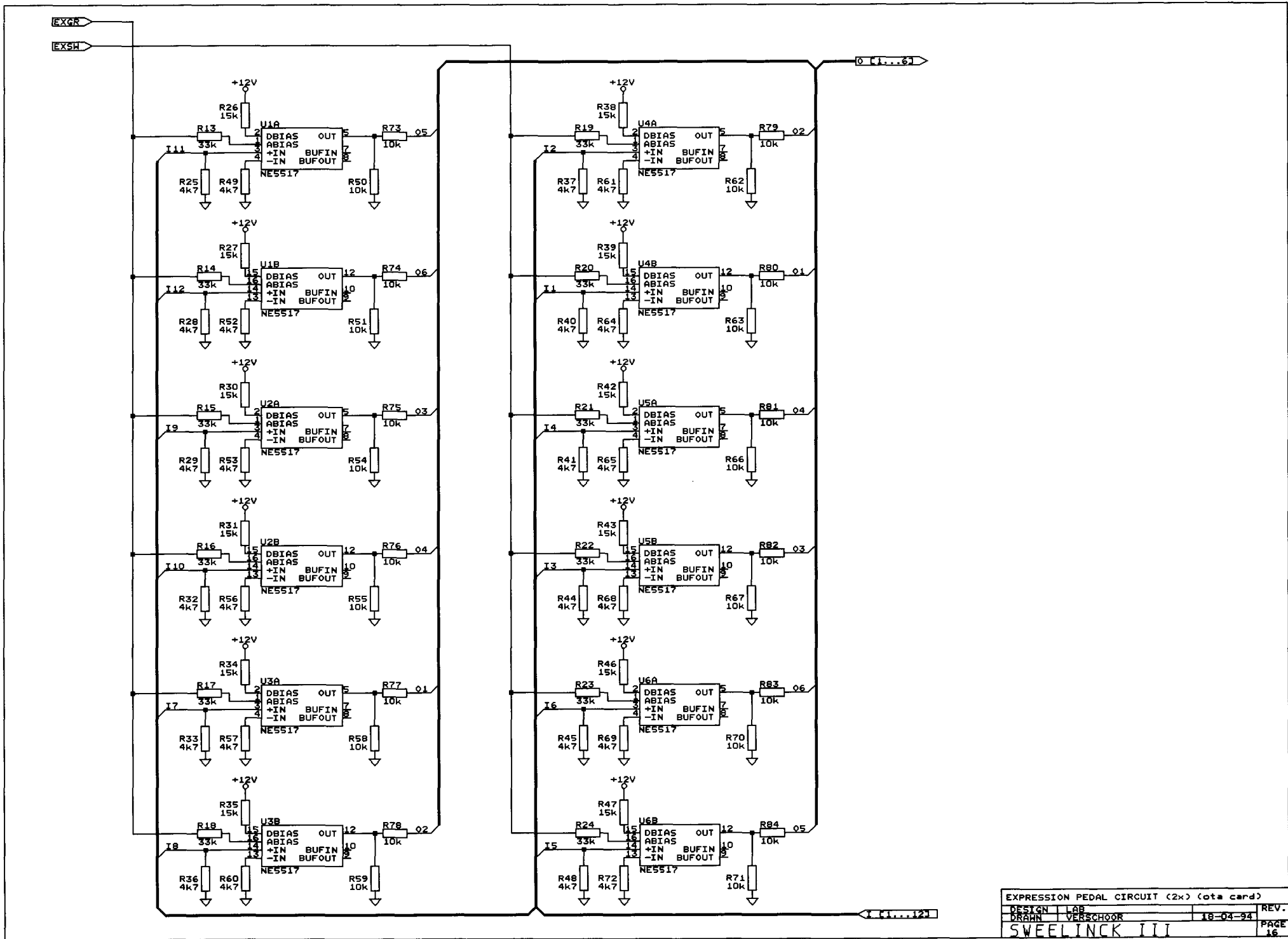

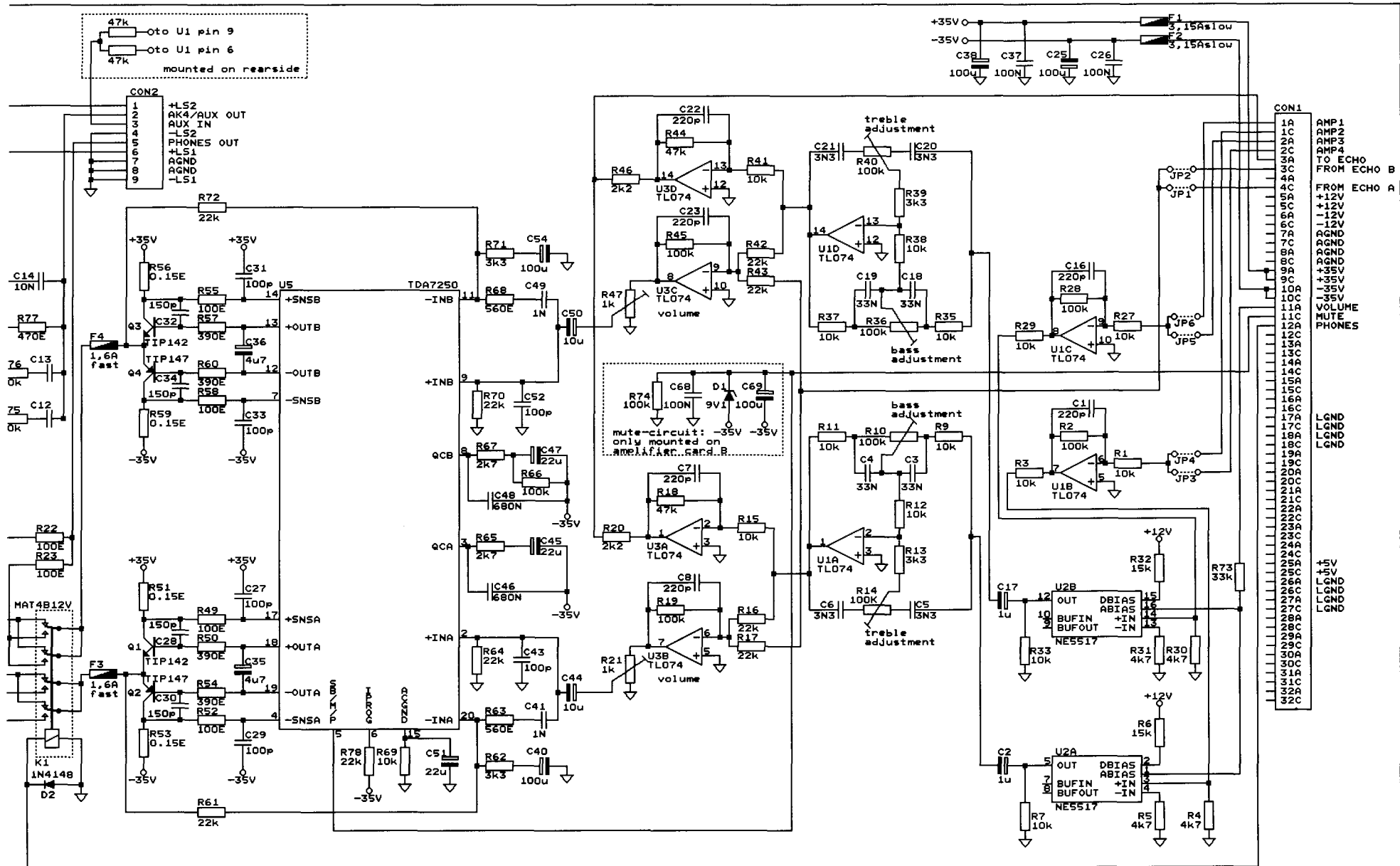

GENERATOR CARD PEDAL/GREAT
(COMPONENT-SIDE VIEW)

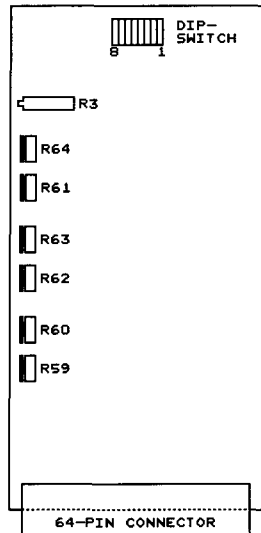

R3 = MAIN TUNING PEDAL/GREAT
 R64 = TREMULANT DEPTH GREAT
 R61 = TREMULANT SPEED GREAT
 R63 = NOT USED
 R62 = NOT USED
 R60 = NOT USED
 R59 = NOT USED
 DS1-DS3 = TUNING PEDAL
 DS4-DS8 = CHORUS INTENSITY PEDAL

GENERATOR CARD CHOIR/SWELL
(COMPONENT-SIDE VIEW)

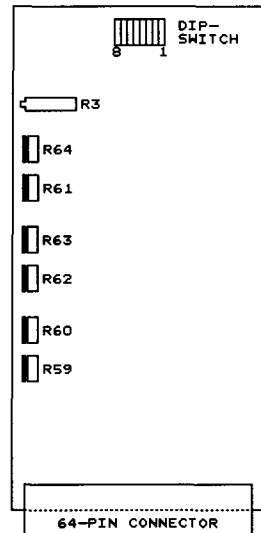

R3 = MAIN TUNING CHOIR/SWELL
 R64 = TREMULANT DEPTH CHOIR
 R61 = TREMULANT SPEED CHOIR
 R63 = TREMULANT DEPTH SWELL
 R62 = TREMULANT SPEED SWELL
 R60 = NOT USED
 R59 = NOT USED
 DS1-DS3 = TUNING SWELL
 DS4-DS8 = CHORUS INTENSITY SWELL

VOICE CARD
(COMPONENT-SIDE VIEW)

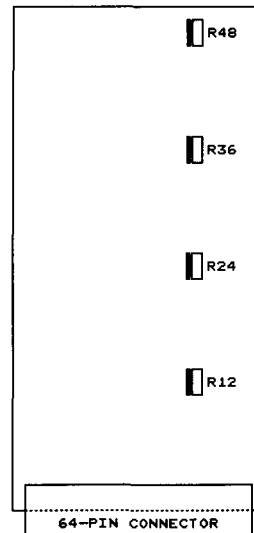

R12 = DC-OFFSET VOICE D
(DISTORSION VOICE D)
 R24 = DC-OFFSET VOICE C
(DISTORSION VOICE C)
 R36 = DC-OFFSET VOICE B
(DISTORSION VOICE B)
 R48 = DC-OFFSET VOICE A
(DISTORSION VOICE A)
 NOTE: R12-R24-R36-R48 ARE NOT
 FOR CHANGING VOLUMES!!
 TURNING THESE POTENTIOMETERS
 WILL GIVE DISTORSION!!

AMPLIFIER CARD
(COMPONENT-SIDE VIEW)

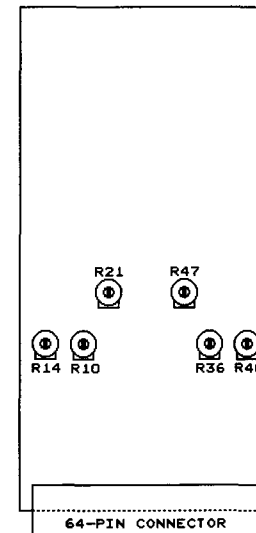

R10 = BASS LEFT AMPLIFIER
 R14 = TREBLE LEFT AMPLIFIER
 R21 = VOLUME LEFT AMPLIFIER
 R36 = BASS RIGHT AMPLIFIER
 R40 = TREBLE RIGHT AMPLIFIER
 R47 = VOLUME RIGHT AMPLIFIER

OTA CARD
(COMPONENT-SIDE VIEW)

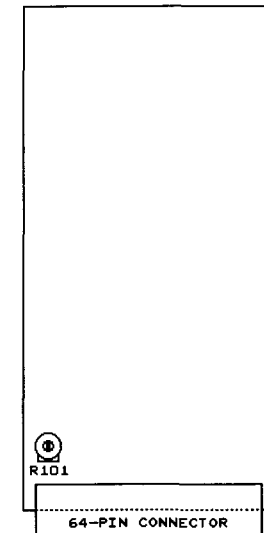

R101 = INPUT AMPLITUDE ECHO

L1 = TUNING GREAT
 L2 = TUNING PEDAL
 R24 = TREMULANT SPEED GREAT
 R27 = TREMULANT DEPTH GREAT
 R42 = NOT USED
 R45 = NOT USED
 R46 = INTENSITY CHORUS PEDAL

L1 = TUNING CHOIR
 L2 = TUNING SWELL
 R24 = TREMULANT SPEED CHOIR
 R27 = TREMULANT DEPTH CHOIR
 R42 = TREMULANT SPEED SWELL
 R45 = TREMULANT DEPTH SWELL
 R46 = INTENSITY CHORUS SWELL